

OMT1 IE4 CATALOGUE

OMT1 IE4 FEATURES

- Cast iron three-phase squirrel cage induction motors
- Efficiency class IE4 according IEC 60034-30
- Voltage: 380-420/660-720V, 50Hz
- Insulation class F, IP55, PTC 150°C, TEFC IC411
- Terminal box: top, Bearing fixation DE
- Regreasable ≥ Framesize 280 standard
- Colour RAL 7031

OMT1 IE4 EIGENSCHAFTEN

- Grauguss, 3-Phasen Käfigläufer-Induktionsmotor
- Wirkungsgradklasse IE4 gemäß IEC 60034-30
- Spannung: 380-420V/660-720V, 50Hz
- Isolationsklasse F, IP55, PTC 150°C, TEFC IC411
- Klemmenkasten: Oberseite, Festlager: A-Seite
- Nachschmiereinrichtung ≥ BG280 standard
- Farbe: RAL 7031

OMT1 IE4 2-POLE | 3000 RPM / OMT1 IE4 2-POHL | 3000 UPM

Frame Size Baugröße	Rated Power Leistung	Rated speed Drehzahl	Rated Torque Moment	Efficiency Leistung	Power factor Leistungsfaktor	Current Strom		Locked Current Anzugsstrom	Locked Torque Anlaufmoment	Max. Torque Kippmoment	Moment of inertia Flächenträgheit	Weight Gewicht
						@400V	@690V					
						P _N kW	n _N 1/min					
160L2	11	2960	35,5	92,6	0,89	19,3	11,2	8,4	3,1	3,7	0,0510	122
160LX2	15	2940	48,7	93,3	0,88	26,5	15,4	7,8	2,6	2,9	0,0637	132
160LY2	18,5	2940	60,1	93,7	0,88	32,4	18,8	7,6	2,3	3,0	0,0765	152
180M2	22	2950	71,2	94,0	0,88	38,3	22,2	7,9	2,7	3,6	0,1170	194
200L2	30	2960	96,7	94,5	0,87	52,7	30,5	7,4	2,4	3,4	0,1737	249
200LX2	37	2960	119,3	94,8	0,87	65,1	37,7	7,6	2,4	3,3	0,2048	264
225M2	45	2950	145,6	95,0	0,88	77,8	45,1	7,8	2,3	3,4	0,30196	336
250M2	55	2970	176,8	95,3	0,89	93,5	54,2	7,1	2,0	3,3	0,4077	416
280S2	75	2975	241	95,6	0,88	128	74,3	6,3	2,0	2,9	0,7988	578
280M2	90	2980	288	95,8	0,88	154	89,3	7,7	2,5	3,7	1,0708	609
315S2	110	2970	354	96,0	0,90	183	106	7,4	2,0	3,2	2,0314	1019
315M2	132	2975	424	96,2	0,91	219	127	7,0	1,8	2,9	2,2065	1082
315L2	160	2970	514	96,3	0,90	267	155	6,6	1,8	3,0	2,4867	1197
315LX2	200	2965	644	96,5	0,91	330	191	6,4	1,9	3,0	2,9069	1281
355M2	250	2980	801	96,5	0,90	414	240	7,7	2,0	3,5	3,8123	1869
355L2	280	2975	898	96,5	0,91	461	267	6,9	1,7	3,1	3,8123	1880
355LX2	315	2980	1009	96,5	0,92	512	297	8,2	2,1	3,8	4,4632	1898
355LY2	355	2975	1139	96,5	0,91	584	338	7,2	1,9	3,4	4,4632	1919

OMT1 IE4 4-POLE | 1500 RPM / OMT1 IE4 4-POHL | 1500 UPM

Frame Size Baugröße	Rated Power Leistung	Rated speed Drehzahl	Rated Torque Moment	Efficiency Leistung	Power factor Leistungsfaktor	Current Strom		Locked Current Anzugsstrom	Locked Torque Anlaufmoment	Max. Torque Kippmoment	Moment of inertia Flächenträgheit	Weight Gewicht
						@400V	@690V					
						P _N kW	n _N 1/min					
160L4	11	1475	71,2	93,3	0,85	20,0	11,6	7,8	2,5	3,1	0,1068	134
160LX4	15	1475	97,1	93,9	0,81	28,5	16,5	7,8	2,9	3,3	0,1287	156
180M4	18,5	1475	119,7	94,2	0,82	34,8	20,2	7,9	2,5	3,6	0,1901	194
180L4	22	1475	142,4	94,5	0,80	42,3	24,5	7,8	2,5	3,8	0,2264	210
200L4	30	1480	193,5	94,9	0,81	56,1	32,5	8,8	2,7	3,5	0,3612	271
225S4	37	1485	238	95,2	0,68	82,4	47,8	6,6	3,2	3,9	0,63	330
225M4	45	1485	289	95,4	0,84	81,1	47,0	7,8	3,2	3,7	0,7384	364
250M4	55	1485	354	95,7	0,86	96,9	56,2	7,7	2,5	3,6	1,0236	425
280S4	75	1490	480	96,0	0,85	133	77,3	7,3	2,6	3,2	2,0828	641
280M4	90	1490	577	96,1	0,86	157	91,2	7,6	2,6	3,4	2,5457	704
315S4	110	1490	705	96,3	0,85	193	112	7,8	3,0	3,9	3,4904	1019
315M4	132	1490	846	96,4	0,88	225	130	8,0	2,9	4,0	4,0139	1113
315L4	160	1490	1025	96,6	0,86	277	160	7,9	3,0	4,1	5,2356	1218
315LX4	200	1490	1281	96,7	0,89	337	196	6,1	2,7	3,3	5,701	1334

OMT1 IE4 4-POLE | 1500 RPM / OMT1 IE4 4-POHL | 1500 UPM

Frame Size Baugröße	Rated Power Leistung	Rated speed Drehzahl	Rated Torque Moment	Efficiency Leistung	Power factor Leistungsfaktor	Current Strom		Locked Current Anzugsstrom	Locked Torque Anlaufmoment	Max. Torque Kippmoment	Moment of inertia Flächenträgheit	Weight Gewicht
						@400V	@690V					
						P _N kW	n _N 1/min					
355M4	250	1490	1602	96,7	0,89	420	244	7,3	2,3	3,5	9,2972	1906
355L4	280	1490	1794	96,7	0,89	468	271	6,5	2,0	3,1	9,2972	2011
355LX4	315	1490	2018	96,7	0,88	533	309	7,0	2,3	3,4	10,2863	2100
355LY4	355	1490	2274	96,7	0,89	593	344	7,2	2,2	3,3	11,2754	2163

OMT1 IE4 6-POLE | 1000 RPM / OMT1 IE4 6-POHL | 1000 UPM

Frame Size Baugröße	Rated Power Leistung	Rated speed Drehzahl	Rated Torque Moment	Efficiency Leistung	Power factor Leistungsfaktor	Current Strom		Locked Current Anzugsstrom	Locked Torque Anlaufmoment	Max. Torque Kippmoment	Moment of inertia Flächenträgheit	Weight Gewicht
						@400V	@690V					
						P _N kW	n _N 1/min					
160L6	8	975	73,4	91,3	0,74	16,0	9,3	6,0	1,9	3,0	0,11698	142
160LX6	11	975	107,7	92,3	0,75	22,9	13,3	6,7	2,1	2,7	0,1775	147
180L6	15	985	145,4	92,9	0,77	30,5	17,7	6,3	2,1	3,1	0,3158	200
200L6	18,5	985	179,3	93,4	0,77	37,1	21,5	7,3	2,4	3,1	0,4684	270
200LX6	22	985	213	93,7	0,78	43,6	25,3	7,5	2,4	3,1	0,5483	323
225M6	30	985	291	94,2	0,82	56,2	32,6	6,8	2,6	3,1	0,8842	331
250M6	37	985	359	94,5	0,84	67,7	39,2	7,3	2,3	3,4	1,1968	431
280S6	45	990	434	94,8	0,84	81	47,1	7,4	2,7	3,5	2,3382	499
280M6	55	990	530	95,1	0,84	99	57,7	8,0	3,2	4,0	2,7975	578
315S6	75	990	723	95,4	0,83	137	80	7,4	2,5	3,4	4,7411	961
315M6	90	990	868	95,6	0,83	163	95	7,6	2,7	3,6	5,8225	1046
315L6	110	990	1061	95,8	0,84	198	115	7,7	2,8	3,7	6,6542	1234
315LX6	132	990	1273	96,0	0,84	237	137	7,8	2,8	3,7	7,9851	1286
355M6	160	990	1543	96,2	0,85	283	164	7,0	1,9	3,3	10,3863	1880
355MX6	185	990	1784	96,2	0,85	328	190	7,3	2,0	3,4	10,893	1932
355MY6	200	990	1928	96,3	0,85	353	205	7,1	1,9	3,3	12,413	1985
355L6	220	990	2121	96,3	0,85	388	225	7,4	2,0	3,5	13,1729	2000
355LX6	250	990	2410	96,5	0,87	431	250	6,7	1,8	2,9	13,9329	2016

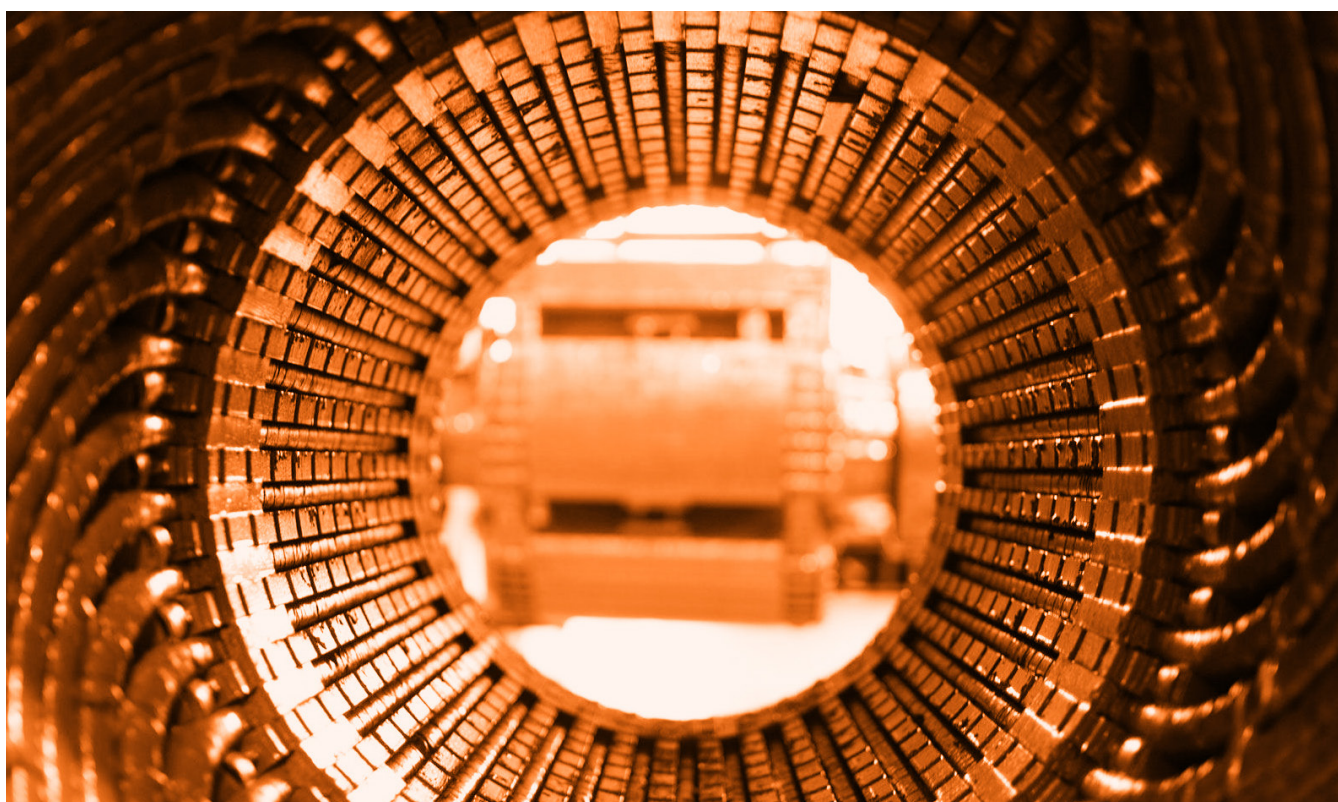

OMT1 IE4 DRAWING B5 / OMT1 IE4 ZEICHNUNG B5

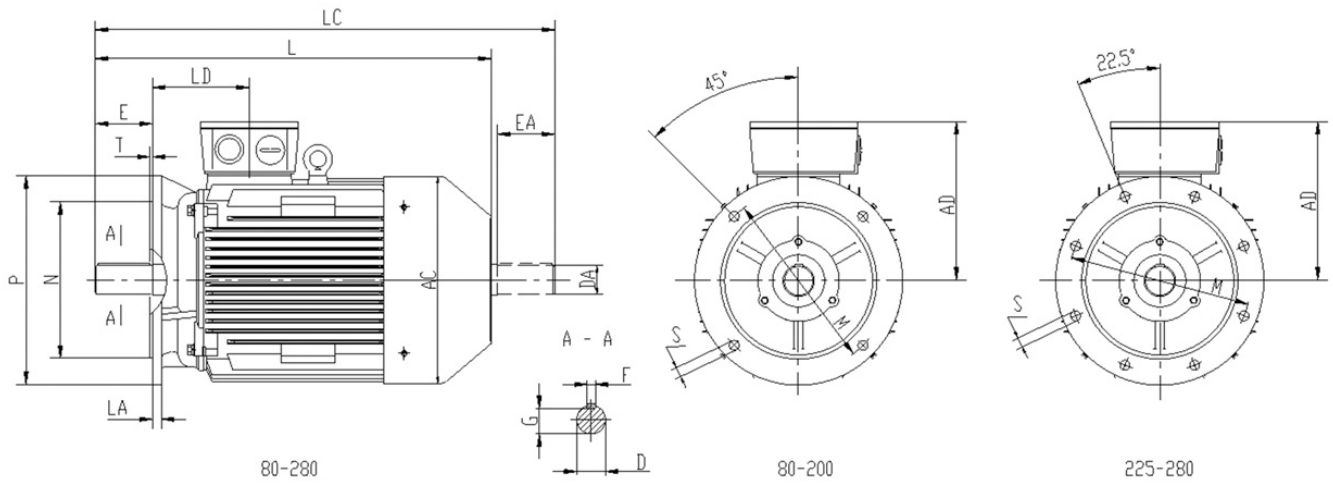

OMT1 IE4 DIMENSIONS B5 / OMT1 IE4 ABMESSUNGEN B5

Frame Size Baugröße	Poles Polzahl	Installation Dimensions / Anlage Abmessungen										Outline Dimensions / Umriss Abmessungen					
		D	E	F	G	M	N	P	R	S	T	AC	AD	LA	LD	L	LC
160L	2-4	42	110	12	37	300	250	350	0	4- Φ 19	5	315	265	15	146	627	764
160L	6-8	42	110	12	37	300	250	350	0	4- Φ 19	5	315	265	15	146	652	764
180M	2,4	48	110	14	42,5	300	250	350	0	4- Φ 19	5	360	280	15	161	650	788
180L	4-8	48	110	14	42,5	300	250	350	0	4- Φ 19	5	360	280	15	161	710	843
200L	2-4	55	110	16	49	350	300	400	0	4- Φ 19	5	400	310	17	186	738	876
200L	6-8	55	110	16	49	350	300	400	0	4- Φ 19	5	400	310	17	186	758	876
225S	4-8	60	140	18	53	400	350	450	0	4- Φ 19	5	450	330	20	189	792	910
225M	2	55	110	16	49	400	350	450	0	4- Φ 19	5	450	330	20	189	768	886
	4-8	60	140	18	53	400	350	450	0	4- Φ 19	5	450	330	20	189	842	960
250M	2	60	140	18	53	500	450	550	0	4- Φ 19	5	485	375	22	207	876	994
	4-8	65	140	18	58	500	450	550	0	4- Φ 19	5	485	375	22	207	910	1028
280S	2	65	140	18	58	500	450	550	0	4- Φ 19	5	550	405	22	215	946	1064
	4-8	75	140	20	67,5	500	450	550	0	4- Φ 19	5	550	405	22	215	1013	1161
280M	2	65	140	18	58	500	450	550	0	4- Φ 19	5	550	405	22	215	991	1109
	4-8	75	140	20	67,5	500	450	550	0	4- Φ 19	5	550	405	22	215	1068	1216



OMT1 IE4 DRAWING V1 / OMT1 IE4 ZEICHNUNG V1

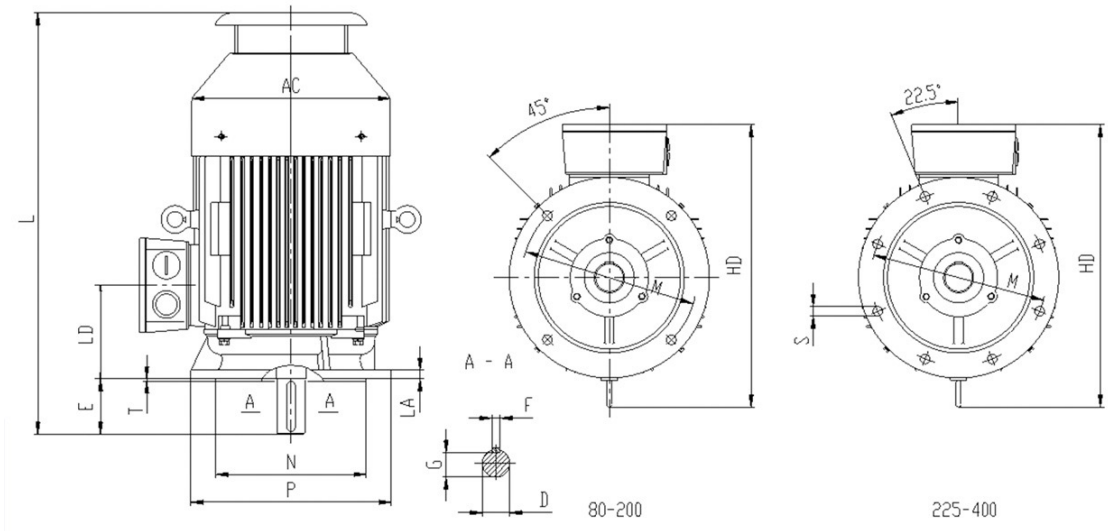

OMT1 IE4 DIMENSIONS V1 / OMT1 IE4 ABMESSUNGEN V1

Frame Size Baugröße	Poles Pohlzahl	Installation Dimensions / Anlage Abmessungen										Outline Dimensions / Umriss Abmessungen				
		D	E	F	G	M	N	P	R	S	T	AC	HD	LA	LD	L
160L	2-4	42	110	12	37	300	250	350	0	4-Φ19	5	315	445	15	146	680
160L	6-8	42	110	12	37	300	250	350	0	4-Φ19	5	315	445	15	146	705
180M	2,4	48	110	14	42,5	300	250	350	0	4-Φ19	5	360	480	15	161	710
180L	4-8	48	110	14	42,5	300	250	350	0	4-Φ19	5	360	480	15	161	770
200L	2-8	55	110	16	49	350	300	400	0	4-Φ19	5	400	530	17	186	818
200L	6-8	55	110	16	49	350	300	400	0	4-Φ19	5	400	530	17	186	838
225S	4-8	60	140	18	53	400	350	450	0	4-Φ19	5	450	575	20	189	887
225M	2	55	110	16	49	400	350	450	0	4-Φ19	5	450	575	20	189	873
	4-8	60	140	18	53	400	350	450	0	4-Φ19	5	450	575	20	189	942
250M	2	60	140	18	53	500	450	550	0	4-Φ19	5	485	635	22	207	971
	4-8	65	140	18	58	500	450	550	0	4-Φ19	5	485	635	22	207	1005
280S	2	65	140	18	58	500	450	550	0	4-Φ19	5	550	725	22	215	1071
	4-8	75	140	20	67,5	500	450	550	0	4-Φ19	5	550	725	22	215	1138
280M	2	65	140	18	58	500	450	550	0	4-Φ19	5	550	725	22	215	1116
	4-8	75	140	20	67,5	500	450	550	0	4-Φ19	5	550	725	22	215	1193
315S	2	65	140	18	58	600	550	660	0	4-Φ24	6	625	865	22	257	1329
	4-8	80	170	22	71	600	550	660	0	4-Φ24	6	625	865	22	257	1345
315M	2	65	140	18	58	600	550	660	0	4-Φ24	6	625	865	22	257	1453
315L	4-8	80	170	22	71	600	550	660	0	4-Φ24	6	625	865	22	257	1483
355M	2	75	140	20	67,5	740	680	800	0	4-Φ24	6	700	970	25	284	1665
355L	4-8	95	170	25	86	740	680	800	0	4-Φ24	6	700	970	25	284	1700



OMT1 IE4 DRAWING B35 / OMT1 IE4 ZEICHNUNG B35

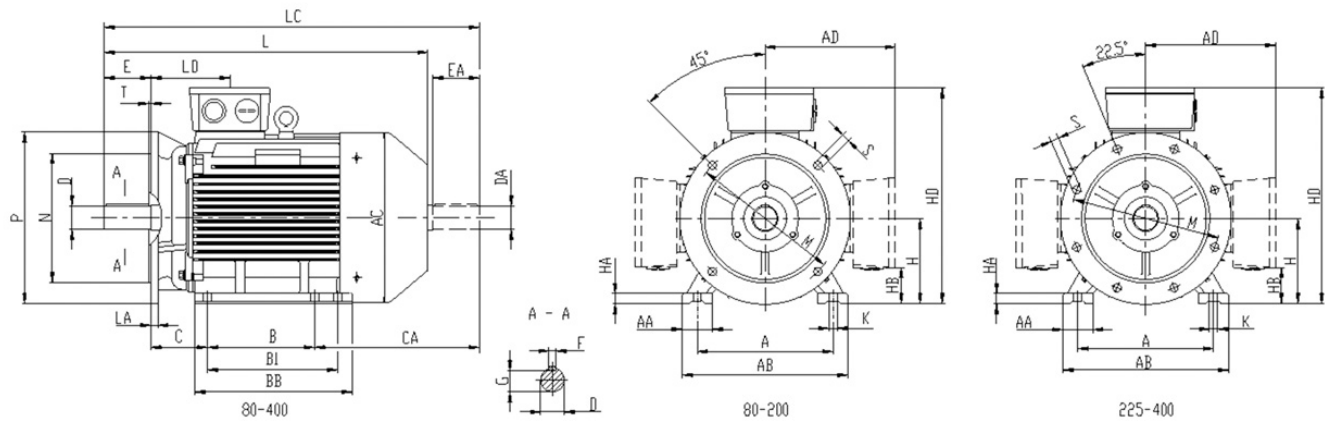

OMT1 IE4 DIMENSIONS B3 & B35 / OMT1 IE4 ABMESSUNGEN B3 & B35

Frame Size Baugröße	Poles Polzahl	Installation Dimensions / Anlage Abmessungen																
		D	E	F	G	A	B	B1	C	CA	H	K	M	N	P	R	S	T
160L	2-4	42	110	12	37	254	210	254	108	188	160	15	300	250	350	0	4-Φ19	5
160L	6-8	42	110	12	37	254	210	254	108	188	160	15	300	250	350	0	4-Φ19	5
180M	2,4	48	110	14	42,5	279	241	-	121	226	180	15	300	250	350	0	4-Φ19	5
180L	4-8	48	110	14	42,5	279	279	-	121	228	180	15	300	250	350	0	4-Φ19	5
200L	2-4	55	110	16	49	318	305	-	133	220	200	19	350	300	400	0	4-Φ19	5
200L	6-8	55	110	16	49	318	305	-	133	220	200	19	350	300	400	0	4-Φ19	5
225S	4-8	60	140	18	53	356	286	-	149	243	225	19	400	350	450	0	4-Φ19	5
225M	2	55	110	16	49	356	311	-	149	243	225	19	400	350	450	0	4-Φ19	5
	4-8	60	140	18	53	356	311	-	149	198	225	19	400	350	450	0	4-Φ19	5
250M	2	60	140	18	53	406	349	-	168	261	250	24	500	450	550	0	4-Φ19	5
	4-8	65	140	18	58	406	349	-	168	261	250	24	500	450	550	0	4-Φ19	5
280S	2	65	140	18	58	457	368	-	190	295	280	24	500	450	550	0	4-Φ19	5
	4-8	75	140	20	67,5	457	368	-	190	315	280	24	500	450	550	0	4-Φ19	5
280M	2	65	140	18	58	457	419	-	190	289	280	24	500	450	550	0	4-Φ19	5
	4-8	75	140	20	67,5	457	419	-	190	319	280	24	500	450	550	0	4-Φ19	5
315S	2	65	140	18	58	508	406	-	216	426	315	28	600	550	660	0	4-Φ24	6
	4-8	80	170	22	71	508	406	-	216	426	315	28	600	550	660	0	4-Φ24	6
315M	2	65	140	18	58	508	457	508	216	485	315	28	600	550	660	0	4-Φ24	6
315L	4-8	80	170	22	71	508	457	508	216	485	315	28	600	550	660	0	4-Φ24	6
355M	2	75	140	20	67,5	610	500	560	254	640	355	28	740	680	800	0	4-Φ24	6
	4-8	95	170	25	86	610	500	560	254	640	355	28	740	680	800	0	4-Φ24	6
355L	2	75	140	20	67,5	610	560	630	254	580	355	28	740	680	800	0	4-Φ24	6
	4-8	95	170	25	86	610	560	630	254	580	355	28	740	680	800	0	4-Φ24	6



OMT1 IE4 DRAWING B3 / OMT1 IE4 ZEICHNUNG B3

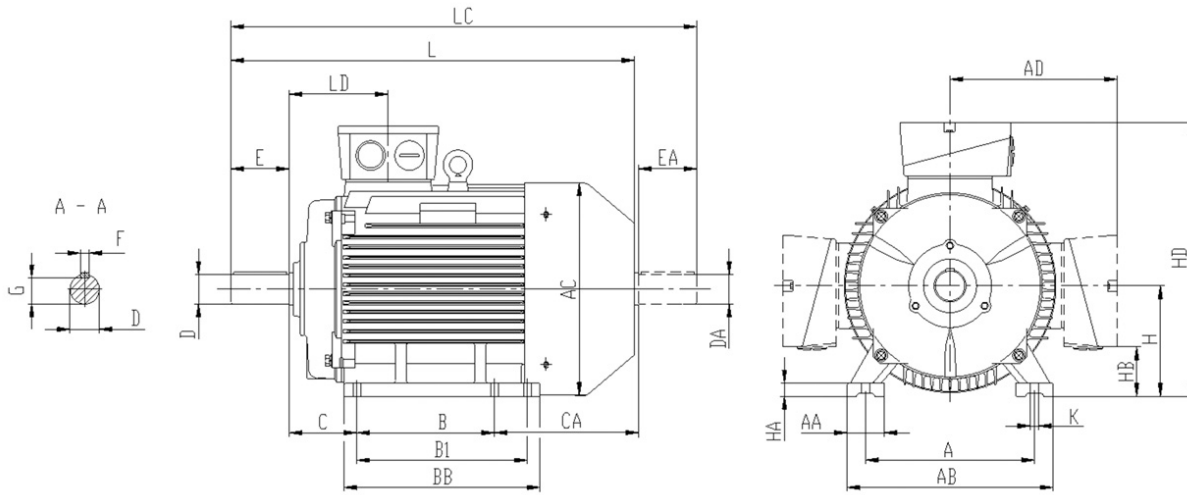

Outline Dimensions / Umriss Abmessungen

AA	AB	AC	AD	BB	HA	HB	HD top	HD left-right	LA	LD	L	LC
65	315	315	265	305	20	81	425	385	15	146	627	745
65	315	315	265	305	20	81	425	385	15	146	652	770
70	350	360	280	315	22	105	460	420	15	161	650	768
70	350	360	280	350	22	105	460	420	15	161	710	828
70	390	400	310	370	25	85	510	475	17	186	738	856
70	390	400	310	370	25	85	510	475	17	186	758	876
75	435	450	335	370	28	110	555	535	20	189	792	910
75	435	450	335	395	28	110	555	535	20	189	768	886
75	435	450	335	395	28	110	555	535	20	189	842	960
80	485	485	375	445	30	110	625	570	22	207	876	994
80	485	485	375	445	30	120	625	570	22	207	910	1028
85	545	550	405	490	35	142	685	660	22	215	946	1064
85	545	550	405	490	35	142	685	660	22	215	1013	1161
85	545	550	405	540	35	142	685	660	22	215	991	1109
85	545	550	405	540	35	142	685	660	22	215	1068	1216
120	630	625	530	570	45	110	845	750	22	257	1169	1317
120	630	625	530	570	45	110	845	750	22	257	1185	1333
120	630	625	530	680	45	110	845	750	22	257	1293	1441
120	630	625	530	680	45	110	845	750	22	257	1323	1501
120	730	700	615	750	52	125	970	830	25	284	1526	1674
120	730	700	615	750	52	125	970	830	25	284	1556	1734
120	730	700	615	750	52	125	970	830	25	284	1526	1674
120	730	700	615	750	52	125	970	830	25	284	1556	1734

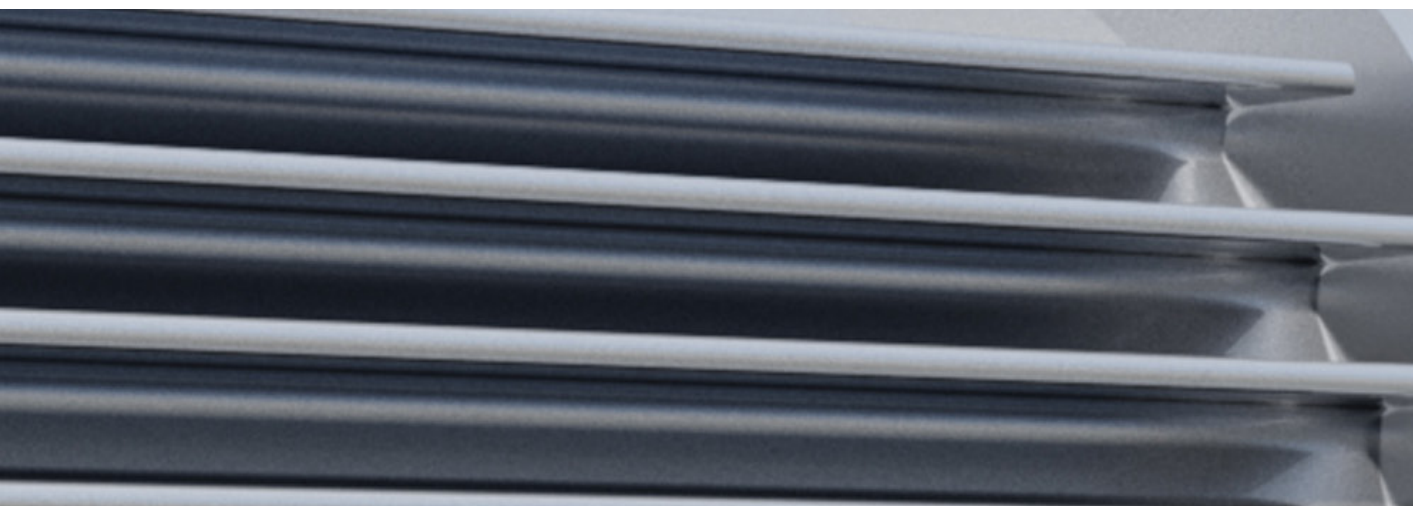

CONTACT DETAILS KONTAKTDATEN

SALES OFFICES | VERKAUFSBÜROS

Main office Arnhem
Broekstraat 32
6828 PZ Arnhem
The Netherlands
+31 (0)26 20 30 200

Germany | Deutschland
Parking 43
46446 Emmerich am Rhein
Germany
+49 (0) 3222 109 007

France | Frankreich
Rue du General Sarrail
59200 Tourcoing
France
+33 (0)320 689 380
contact@espacemoteurs.com



DISTRIBUTION NETWORK | VERTRIEBSNETZWERK

Algeria
Austria
Belgium
Bolivia
Bosnia-Herzegovina
Bulgaria
Croatia
Czech republic
Denmark

Egypt
Estland
Finland
France
Germany
Hong Kong
Hungary
India
Irán

Iraq
Ireland
Israel
Italy
Jordan
Kazachstan
Kenia
Kosovo
Latvia

Libia
Lithuania
Macedonia
Morocco
Norway
Pakistan
Philippines
Poland
Portugal

Romania
Russia
Serbia
Slovakia
Slovenia
South Africa
Spain
Sweden
Switzerland

Taiwan
Thailand
The Netherlands
U.S.A.
U.A.E.
U.K.
Ukraine
Vietnam

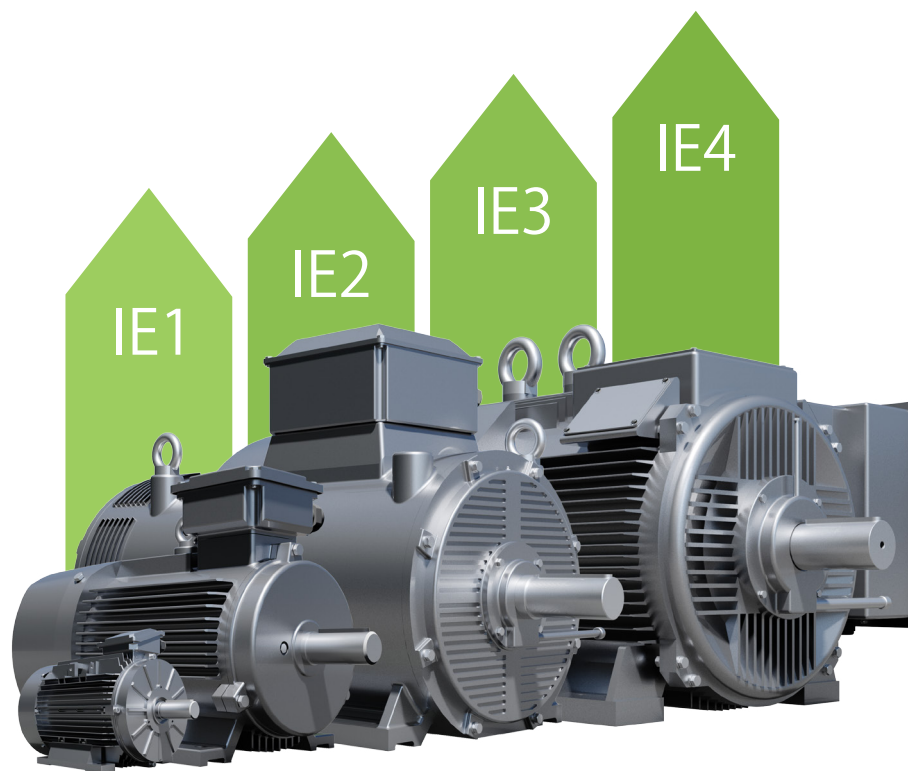

EMPOWERING THE FUTURE OF INDUSTRY
DIE ZUKUNFT DER INDUSTRIE UNTERSTÜTZEN