

Réducteurs à arbres parallèles F

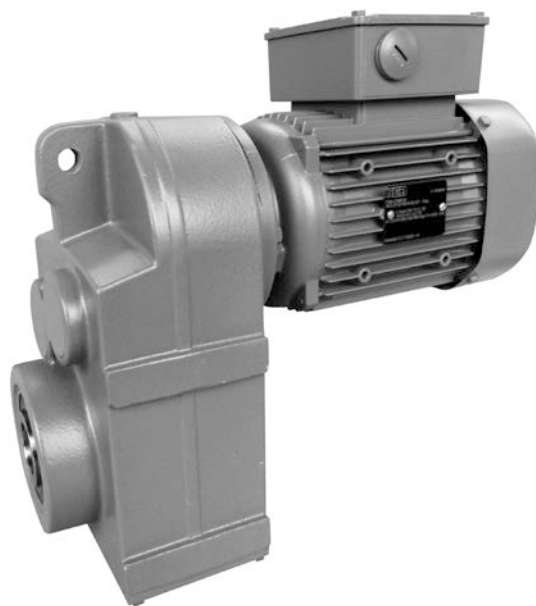

Types de construction

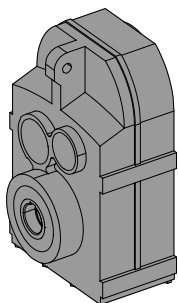

Montage flottant
Arbre creux avec rainure de clavette
Exemple: F42A

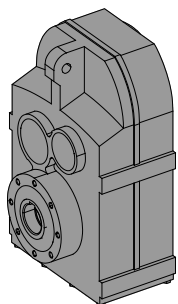

Montage flottant
Arbre creux avec rainure de clavette
Exemple: F53B

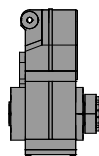
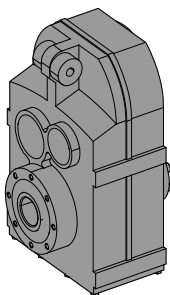

Montage flottant
Arbre creux avec frette de serrage
Amortisseurs élastiques
Exemple: F32BSG

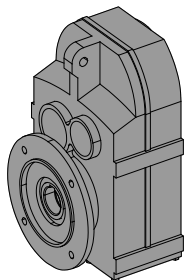

Version à bride
 Arbre creux avec rainure de clavette
 Exemple: **F33C**

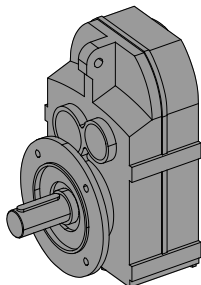

Version à bride
 Arbre de sortie avec clavette
 Exemple: **F42CV**

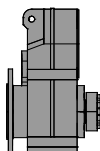
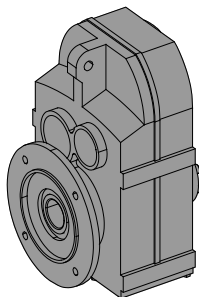

Version à bride
 Arbre creux avec frette de serrage
 Exemple: **F52CS**

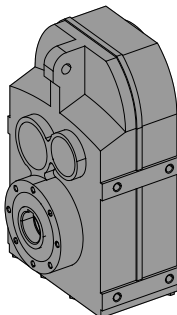

Exécution montage flottant + faces latérales
 Arbre creux avec rainure de clavette
 Exemple: **F43D**

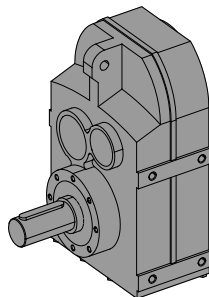

Exécution montage flottant + faces latérales
 Arbre de sortie avec clavette
 Exemple: **F32DV**

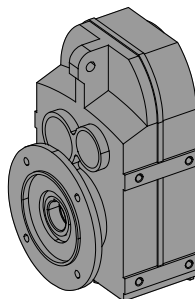

Exécution à bride + faces latérales
 Arbre creux avec rainure de clavette
 Exemple: **F42E**

Tableaux de sélection - Réducteurs

i	n2 [1/min]	T2max [Nm]	P1max [kW]
n1=1400 1/min			
F23G03			
9125.4	0.15	245	<0.05
7709.2	0.18	245	<0.05
6591.1	0.21	245	<0.05
5686.0	0.25	245	<0.05
4938.4	0.28	245	<0.05
4310.3	0.32	245	<0.05
3720.4	0.38	245	<0.05
3209.5	0.44	245	<0.05
2787.5	0.50	245	<0.05
2433.0	0.58	245	<0.05

i	n2 [1/min]	T2max [Nm]	P1max [kW]
n1=1400 1/min			
F23G02			
2135.7	0.66	245	<0.05
1804.3	0.78	245	<0.05
1542.6	0.91	245	<0.05
1330.8	1.1	245	<0.05
1155.8	1.2	245	<0.05
1008.8	1.4	245	<0.05
883.58	1.6	245	<0.05
759.44	1.8	245	<0.05
655.15	2.1	245	0.05
569.00	2.5	245	0.06
496.64	2.8	245	0.07
434.99	3.2	245	0.08
380.22	3.7	245	0.09
334.98	4.2	245	0.11
296.97	4.7	245	0.12
266.48	5.3	245	0.13
232.93	6.0	245	0.15
205.21	6.8	245	0.18
181.93	7.7	245	0.20

i	n2 [1/min]	T2max [Nm]	P1max [kW]
n1=1400 1/min			
F23			
170.20	8.2	245	0.21
145.41	9.6	245	0.25
125.84	11	245	0.29
109.99	13	245	0.33
96.90	14	245	0.37
85.91	16	245	0.42
77.09	18	245	0.47
67.38	21	245	0.53
59.37	24	245	0.61
52.63	27	245	0.68
46.08	30	245	0.78
40.60	34	245	0.88
35.99	39	245	1.00
32.07	44	245	1.12
28.79	49	245	1.25
25.12	56	245	1.43
22.01	64	230	1.53

i	n2 [1/min]	T2max [Nm]	P1max [kW]
n1=1400 1/min			
F22			
32.42	43	245	1.11
27.83	50	245	1.29
24.21	58	245	1.48
21.28	66	245	1.69
18.86	74	245	1.90
16.82	83	245	2.13
15.09	93	240	2.33
13.71	102	235	2.51
12.09	116	225	2.73
10.71	131	215	2.94
9.58	146	205	3.00
8.34	168	193	3.00
7.62	184	165	3.00
6.80	206	160	3.00
6.10	230	150	3.00
5.54	253	142	3.00
4.89	287	132	3.00
4.33	324	122	3.00
3.87	362	114	3.00
3.37	415	104	3.00

i	n2 [1/min]	T2max [Nm]	P1max [kW]
n1=1400 1/min			
F33G13			
12764	0.11	470	<0.05
10821	0.13	470	<0.05
9286.8	0.15	470	<0.05
8044.8	0.17	470	<0.05
7018.8	0.20	470	<0.05
6157.0	0.23	470	<0.05
5422.8	0.26	470	<0.05
4768.5	0.29	470	<0.05
4092.4	0.34	470	<0.05
3545.1	0.39	470	<0.05
3092.9	0.45	470	<0.05

i	n2 [1/min]	T2max [Nm]	P1max [kW]
n1=1400 1/min			
F33G12			
2753.1	0.51	470	<0.05
2352.1	0.60	470	<0.05
2035.5	0.69	470	<0.05
1779.2	0.79	470	<0.05
1567.5	0.89	470	<0.05
1389.7	1.0	470	<0.05
1238.2	1.1	470	0.06
1111.5	1.3	470	0.06
970.15	1.4	470	0.07
849.73	1.6	470	0.08
781.01	1.8	470	0.09
688.08	2.0	470	0.10
610.01	2.3	470	0.11
543.51	2.6	470	0.13
487.91	2.9	470	0.14
425.86	3.3	470	0.16
373.00	3.8	470	0.19
332.76	4.2	470	0.21
298.48	4.7	470	0.23
271.27	5.2	470	0.25
239.17	5.9	470	0.29
211.83	6.6	470	0.33

i	n2 [1/min]	T2max [Nm]	P1max [kW]
n1=1400 1/min			
F33			
190.26	7.4	470	0.36
163.34	8.6	470	0.42
142.09	9.9	470	0.49
124.88	11	470	0.55
110.67	13	470	0.62
98.73	14	470	0.70
88.56	16	470	0.78
80.49	17	470	0.86
70.96	20	470	0.97
62.85	22	470	1.10
56.24	25	470	1.23
49.17	28	470	1.40
43.87	32	470	1.57
39.35	36	470	1.75
35.76	39	470	1.93
31.53	44	470	2.19
27.93	50	470	2.47
24.99	56	470	2.76
21.75	64	465	3.13

i	n2 [1/min]	T2max [Nm]	P1max [kW]
n1=1400 1/min			
F32			
27.55	51	470	2.51
24.60	57	470	2.81
22.12	63	470	3.12
20.01	70	465	3.41
18.24	77	450	3.62
16.27	86	435	3.92
14.60	96	425	4.00
13.24	106	415	4.00
11.74	119	400	4.00
10.33	136	385	4.00
9.05	155	375	4.00
8.50	165	245	4.00
7.95	176	360	4.00
7.58	185	235	4.00
6.80	206	225	4.00
6.17	227	215	4.00
5.47	256	205	4.00
4.81	291	192	4.00
4.21	332	181	4.00
3.70	378	170	4.00

i	n2 [1/min]	T2max [Nm]	P1max [kW]
n1=1400 1/min			
F43G13			
16236	0.086	885	<0.05
13764	0.10	885	<0.05
11813	0.12	885	<0.05
10233	0.14	885	<0.05
8927.9	0.16	885	<0.05
7831.6	0.18	885	<0.05
6897.8	0.20	885	<0.05
6065.5	0.23	885	<0.05
5205.5	0.27	885	<0.05
4509.3	0.31	885	<0.05
3934.2	0.36	885	<0.05

i	n2 [1/min]	T2max [Nm]	P1max [kW]
n1=1400 1/min			
F43G12			
3501.9	0.40	885	<0.05
2991.9	0.47	885	<0.05
2589.2	0.54	885	<0.05
2263.2	0.62	885	0.06
1993.9	0.70	885	0.06
1767.6	0.79	885	0.07
1574.9	0.89	885	0.08
1413.8	0.99	885	0.09
1234.0	1.1	885	0.10
1080.8	1.3	885	0.12
993.44	1.4	885	0.13
875.23	1.6	885	0.15
775.93	1.8	885	0.17
691.34	2.0	885	0.19
620.62	2.3	885	0.21
541.69	2.6	885	0.24
474.45	3.0	885	0.27
426.68	3.3	885	0.30
386.00	3.6	885	0.34
351.84	4.0	885	0.37
313.88	4.5	885	0.41
281.55	5.0	885	0.46
255.44	5.5	885	0.51
226.36	6.2	885	0.57
199.24	7.0	885	0.65

i	n2 [1/min]	T2max [Nm]	P1max [kW]
n1=1400 1/min			
F43			
235.25	6.0	885	0.55
203.29	6.9	885	0.64
178.07	7.9	885	0.73
157.64	8.9	885	0.82
140.77	9.9	885	0.92
126.60	11	885	1.02
114.53	12	885	1.13
104.39	13	885	1.24
93.13	15	885	1.39
83.54	17	885	1.55
75.79	18	885	1.71
67.16	21	885	1.93
59.12	24	885	2.19
51.77	27	885	2.50
46.92	30	885	2.76
42.08	33	885	3.08
38.18	37	885	3.39
33.83	41	885	3.83
29.78	47	885	4.35
26.08	54	850	4.78
22.91	61	785	5.0

i	n2 [1/min] n1=1400 1/min	T2max [Nm]	P1max [kW]
F42			
30.05	47	885	4.31
27.14	52	885	4.77
24.65	57	885	5.3
22.54	62	885	5.7
20.22	69	885	6.4
18.25	77	885	7.1
16.80	83	885	7.5
15.02	93	885	7.5
13.33	105	885	7.5
11.82	118	885	7.5
10.51	133	885	7.5
9.01	155	885	7.5
7.94	176	885	7.5
7.36	190	440	7.5
6.77	207	570	7.5
6.05	231	555	7.5
5.38	260	565	7.5
4.76	294	535	7.5
4.24	330	505	7.5
3.63	385	470	7.5
3.20	437	440	7.5

i	n2 [1/min]	T2max [Nm]	P1max [kW]
F53G23			
16911	0.083	1580	<0.05
14448	0.097	1580	<0.05
12503	0.11	1580	<0.05
10929	0.13	1580	<0.05
9628.5	0.15	1580	<0.05
8536.1	0.16	1580	<0.05
7659.6	0.18	1580	<0.05
6695.2	0.21	1580	<0.05
5898.5	0.24	1580	<0.05
5229.3	0.27	1580	<0.05
4578.3	0.31	1580	0.05
4033.5	0.35	1580	0.06
3575.9	0.39	1580	0.06

i	n2 [1/min]	T2max [Nm]	P1max [kW]
F53G22			
3221.2	0.43	1580	0.07
2765.4	0.51	1580	0.08
2405.6	0.58	1580	0.10
2114.3	0.66	1580	0.11
1873.6	0.75	1580	0.12
1671.5	0.84	1580	0.14
1499.3	0.93	1580	0.15
1362.7	1.0	1580	0.17
1201.4	1.2	1580	0.19
1064.0	1.3	1580	0.22
960.29	1.5	1580	0.24
883.90	1.6	1580	0.26
776.06	1.8	1580	0.30
696.12	2.0	1580	0.33
632.66	2.2	1580	0.37
557.80	2.5	1580	0.42
494.02	2.8	1580	0.47
445.85	3.1	1580	0.52
410.38	3.4	1580	0.57
366.79	3.8	1580	0.63
325.70	4.3	1580	0.71
288.62	4.9	1580	0.80
252.64	5.5	1580	0.92
228.00	6.1	1580	1.02
209.86	6.7	1580	1.11
196.76	7.1	1580	1.18

i	n2 [1/min]	T2max [Nm]	P1max [kW]
F53			
205.64	6.8	1580	1.13
182.73	7.7	1580	1.27
163.81	8.5	1580	1.42
147.91	9.5	1580	1.57
134.37	10	1580	1.73
122.86	11	1580	1.89
110.24	13	1580	2.11
99.49	14	1580	2.33
91.57	15	1580	2.54
81.85	17	1580	2.84
72.68	19	1580	3.20
64.40	22	1580	3.61
56.37	25	1580	4.12
50.88	28	1580	4.56
46.83	30	1580	4.96
41.85	33	1580	5.5
37.17	38	1580	6.2
32.93	43	1580	7.1
29.31	48	1580	7.9
25.11	56	1580	9.2
22.15	63	1480	9.8

i	n2 [1/min]	T2max [Nm]	P1max [kW]
F52			
34.34	41	1460	6.2
31.33	45	1450	6.8
28.82	49	1580	8.1
26.01	54	1580	8.9
23.61	59	1580	9.8
21.83	64	1580	10.6
19.67	71	1580	11.8
17.62	79	1580	13.2
15.78	89	1580	14.7
14.20	99	1580	15.0
12.39	113	1580	15.0
11.10	126	1530	15.0
9.85	142	1480	15.0
8.65	162	1430	15.0
7.74	181	910	15.0
6.94	202	870	15.0
6.24	224	835	15.0
5.45	257	785	15.0
4.88	287	750	15.0
4.33	323	710	15.0
3.80	368	665	15.0

i	n2 [1/min]	T2max [Nm]	P1max [kW]
F63G23			
20876	0.067	2800	<0.05
17836	0.078	2800	<0.05
15435	0.091	2800	<0.05
13492	0.10	2800	<0.05
11886	0.12	2800	<0.05
10538	0.13	2800	<0.05
9455.6	0.15	2800	<0.05
8265.1	0.17	2800	<0.05
7281.6	0.19	2800	0.06
6455.5	0.22	2800	0.06
5651.9	0.25	2800	0.07
4979.3	0.28	2800	0.08
4414.4	0.32	2800	0.09

i	n2 [1/min]	T2max [Nm]	P1max [kW]
F63G22			
3976.5	0.35	2800	0.10
3413.8	0.41	2800	0.12
2969.6	0.47	2800	0.14
2610.0	0.54	2800	0.16
2313.0	0.61	2800	0.18
2063.5	0.68	2800	0.20
1850.9	0.76	2800	0.22
1682.2	0.83	2800	0.24
1483.1	0.94	2800	0.28
1313.5	1.1	2800	0.31
1214.4	1.2	2800	0.34
1094.0	1.3	2800	0.38
958.03	1.5	2800	0.43
859.35	1.6	2800	0.48
781.01	1.8	2800	0.53
688.59	2.0	2800	0.60
609.86	2.3	2800	0.67
563.82	2.5	2800	0.73
507.91	2.8	2800	0.81
455.13	3.1	2800	0.90
407.58	3.4	2800	1.01
366.82	3.8	2800	1.12
320.02	4.4	2800	1.28
286.71	4.9	2800	1.43
254.33	5.5	2800	1.62

i	n2 [1/min]	T2max [Nm]	P1max [kW]
F63			
242.53	5.8	2800	1.69
218.27	6.4	2800	1.88
197.90	7.1	2800	2.08
180.55	7.8	2800	2.28
166.08	8.4	2800	2.47
149.88	9.3	2800	2.74
136.08	10	2800	3.02
125.81	11	2800	3.27
113.33	12	2800	3.63
101.56	14	2800	4.05
90.95	15	2800	4.52
81.85	17	2800	5.0
71.41	20	2800	5.8
63.98	22	2800	6.4
56.75	25	2800	7.2
49.31	28	2800	8.3
44.16	32	2800	9.3
39.74	35	2800	10.3
34.67	40	2800	11.9
31.06	45	2780	13.1
27.56	51	2590	13.8
24.21	58	2390	14.5

i	n2 [1/min]	T2max [Nm]	P1max [kW]
F62			
34.05	41	2550	11.0
31.05	45	2520	11.9
28.80	49	2800	14.3
26.09	54	2800	15.7
23.73	59	2800	17.3
21.42	65	2800	19.2
19.43	72	2760	20.8
16.83	83	2650	22.0
15.23	92	2580	22.0
13.82	101	2510	22.0
12.33	114	2430	22.0
10.45	134	2320	22.0
8.92	157	2220	22.0
7.70	182	1440	22.0
6.97	201	1400	22.0
6.33	221	1340	22.0
5.64	248	1280	22.0
4.78	293	1190	22.0
4.08	343	1100	22.0

i	n2 [1/min]	T2max [Nm]	P1max [kW]
F73G33			
21379	0.065	4880	<0.05
18354	0.076	4880	<0.05
15966	0.088	4880	<0.05
14033	0.100	4880	0.05
12436	0.11	4880	0.06
11094	0.13	4880	0.06
9951.3	0.14	4880	0.07
9044.1	0.15	4880	0.08
7973.9	0.18	4880	0.09
7062.2	0.20	4880	0.10
6407.0	0.22	4880	0.11
5550.0	0.25	4880	0.13
4929.5	0.28	4880	0.15
4421.8	0.32	4880	0.16
4018.7	0.35	4880	0.18
3543.1	0.40	4880	0.20

i	n2 [1/min]	T2max [Nm]	P1max [kW]
F73G32			
3095.5	0.45	4880	0.23
2764.2	0.51	4880	0.26
2485.9	0.56	4880	0.29
2248.8	0.62	4880	0.32
2049.8	0.68	4880	0.35
1828.7	0.77	4880	0.39
1640.3	0.85	4880	0.44
1488.1	0.94	4880	0.48
1289.1	1.1	4880	0.55
1166.4	1.2	4880	0.61
1058.9	1.3	4880	0.68
944.12	1.5	4880	0.76
879.92	1.6	4880	0.81
789.28	1.8	4880	0.91
716.05	2.0	4880	1.00
620.27	2.3	4880	1.15
561.22	2.5	4880	1.27
509.49	2.7	4880	1.40
454.28	3.1	4880	1.57
385.26	3.6	4880	1.86
347.80	4.0	4880	2.06
315.75	4.4	4880	2.26
281.53	5.0	4880	2.54
238.76	5.9	4880	2.99

i	n2 [1/min] n1=1400 1/min	T2max [Nm]	P1max [kW]
F73			
274.23	5.1	4880	2.61
249.41	5.6	4880	2.87
228.27	6.1	4880	3.13
211.55	6.6	4880	3.38
191.74	7.3	4880	3.73
174.87	8.0	4880	4.09
162.19	8.6	4880	4.41
146.94	9.5	4880	4.87
133.66	10	4880	5.3
120.60	12	4880	5.9
109.41	13	4880	6.5
94.78	15	4880	7.5
85.76	16	4880	8.3
77.85	18	4880	9.2
69.41	20	4880	10.3
58.87	24	4880	12.1
51.81	27	4880	13.8
44.88	31	4880	15.9
40.61	34	4810	17.4
36.86	38	4630	18.4
32.87	43	4410	19.7
27.88	50	4100	21.6
23.79	59	3810	23.5

i	n2 [1/min] n1=1400 1/min	T2max [Nm]	P1max [kW]
F72			
28.53	49	4430	22.8
25.85	54	4300	24.4
23.54	59	4190	26.1
20.62	68	4030	28.6
18.76	75	3920	30.0
16.90	83	3800	30.0
15.17	92	3690	30.0
13.01	108	3530	30.0
11.25	124	3390	30.0
9.78	143	3260	30.0
9.11	154	2240	30.0
8.29	169	2160	30.0
7.46	188	2070	30.0
6.70	209	1980	30.0
5.75	244	1860	30.0
4.97	282	1740	30.0
4.32	324	1630	30.0

i	n2 [1/min]	T2max [Nm]	P1max [kW]
F83G33			
22582	0.062	8900	0.06
19387	0.072	8900	0.07
16864	0.083	8900	0.08
14822	0.094	8900	0.09
13135	0.11	8900	0.10
11718	0.12	8900	0.11
10511	0.13	8900	0.12
9552.8	0.15	8900	0.14
8422.4	0.17	8900	0.15
7459.4	0.19	8900	0.17
6586.0	0.21	8900	0.20
5836.4	0.24	8900	0.22
5206.8	0.27	8900	0.25
4670.4	0.30	8900	0.28
4244.7	0.33	8900	0.31
3742.4	0.37	8900	0.35

i	n2 [1/min] n1=1400 1/min	T2max [Nm]	P1max [kW]
F83G32			
3269.6	0.43	8900	0.40
2919.6	0.48	8900	0.45
2625.7	0.53	8900	0.50
2375.3	0.59	8900	0.55
2165.1	0.65	8900	0.60
1931.5	0.72	8900	0.68
1732.6	0.81	8900	0.75
1578.2	0.89	8900	0.83
1382.4	1.0	8900	0.94
1257.5	1.1	8900	1.04
1132.6	1.2	8900	1.15
1016.9	1.4	8900	1.28
929.40	1.5	8900	1.40
833.66	1.7	8900	1.57
756.35	1.9	8900	1.73
670.24	2.1	8900	1.95
589.95	2.4	8900	2.21
516.64	2.7	8900	2.53
470.60	3.0	8900	2.77
412.22	3.4	8900	3.17
374.97	3.7	8900	3.48
337.74	4.1	8900	3.86
303.24	4.6	8900	4.30
260.13	5.4	8900	5.0
228.49	6.1	8900	5.7

i	n2 [1/min] n1=1400 1/min	T2max [Nm]	P1max [kW]
F83			
200.61	7.0	8900	6.5
183.42	7.6	8900	7.1
169.54	8.3	8900	7.7
154.08	9.1	8900	8.5
140.63	10.0	8900	9.3
127.39	11	8900	10.2
116.03	12	8900	11.2
101.64	14	8900	12.8
92.45	15	8900	14.1
83.27	17	8900	15.7
74.77	19	8900	17.5
64.14	22	8900	20.3
55.44	25	8900	23.5
48.19	29	8850	26.9
41.43	34	8540	30.2
37.20	38	8260	32.6
31.91	44	7890	36.3
27.58	51	7550	40.1
23.97	58	7240	44.3

i	n2 [1/min]	T2max [Nm]	P1max [kW]
F82			
20.19	69	6480	45.0
18.25	77	6290	45.0
15.83	88	6040	45.0
13.85	101	5810	45.0
12.20	115	5600	45.0
10.08	139	3790	45.0
9.11	154	3650	45.0
7.90	177	3450	45.0
6.92	202	3270	45.0
6.09	230	3100	45.0

Tableaux de sélection - Motoréducteurs

Type	n2 [1/min]	T2 [Nm]	cG	i	-kg
0.12 kW					
F33G12A DM63K4					26
2.8	390	1.20	487.91		
3.2	340	1.40	425.86		
3.7	295	1.60	373.00		
4.1	265	1.80	332.76		
4.6	240	2.00	298.48		
F23G02A DM63K4					18
3.6	305	0.80	380.22		
4.1	265	0.90	334.98		
4.6	235	1.05	296.97		
5.2	210	1.15	266.48		
5.9	186	1.30	232.93		
6.7	164	1.50	205.21		
7.6	145	1.70	181.93		
F23A DM63K4					14
8.1	141	1.75	170.20		
9.5	121	2.0	145.41		
11	104	2.3	125.84		
13	91	2.7	109.99		
14	80	3.0	96.90		
16	71	3.4	85.91		
18	64	3.8	77.09		
20	56	4.4	67.38		
23	49	5.0	59.37		
26	44	5.6	52.63		
30	38	6.4	46.08		
34	34	7.3	40.60		
38	30	8.2	35.99		
43	27	9.2	32.07		
48	24	10	28.79		
55	21	12	25.12		
63	18	13	22.01		
F22A DM63K4					14
43	27	9.1	32.42		
50	23	11	27.83		
57	20	12	24.21		
65	18	14	21.28		
73	16	16	18.86		
82	14	18	16.82		
91	13	19	15.09		
101	11	21	13.71		
114	10	22	12.09		
129	8.9	24	10.71		
181	6.3	26	7.62		
203	5.6	28	6.80		
226	5.1	30	6.10		
249	4.6	31	5.54		
282	4.1	33	4.89		
319	3.6	34	4.33		
0.18 kW					
F43G12A DM63G4					38
2.9	565	1.55	474.45		
3.2	510	1.75	426.68		
3.6	460	1.90	386.00		
F33G12A DM63G4					27
2.8	585	0.80	487.91		
3.2	510	0.90	425.86		
3.7	445	1.05	373.00		
4.1	400	1.20	332.76		
4.6	355	1.30	298.48		
5.1	325	1.45	271.27		
5.8	285	1.65	239.17		
6.5	255	1.85	211.83		
F33A DM63G4					21
7.3	235	2.00	190.26		
Type	n2 [1/min]	T2 [Nm]	cG	i	-kg
0.25 kW					
F23G02A DM63G4					18
5.9	280	0.90	232.93		
6.7	245	1.00	205.21		
7.6	220	1.15	181.93		
F23A DM63G4					15
8.1	210	1.15	170.20		
9.5	181	1.35	145.41		
11	157	1.55	125.84		
13	137	1.80	109.99		
14	121	2.0	96.90		
16	107	2.3	85.91		
18	96	2.6	77.09		
20	84	2.9	67.38		
23	74	3.3	59.37		
26	66	3.7	52.63		
30	57	4.3	46.08		
34	51	4.8	40.60		
38	45	5.5	35.99		
43	40	6.1	32.07		
48	36	6.8	28.79		
55	31	7.8	25.12		
63	27	8.4	22.01		
F22A DM63G4					15
43	40	6.1	32.42		
50	35	7.1	27.83		
57	30	8.1	24.21		
65	27	9.2	21.28		
73	23	10	18.86		
82	21	12	16.82		
91	19	13	15.09		
101	17	14	13.71		
114	15	15	12.09		
129	13	16	10.71		
181	9.5	17	7.62		
203	8.5	19	6.80		
226	7.6	20	6.10		
249	6.9	21	5.54		
282	6.1	22	4.89		
319	5.4	23	4.33		
F53G22A DM71K4					63
2.9	805	1.95	494.02		
F43G12A DM71K4					38
3.0	770	1.15	474.45		
3.3	695	1.25	426.68		
3.7	625	1.40	386.00		
4.0	570	1.55	351.84		
4.5	510	1.75	313.88		
5.0	460	1.95	281.55		
F33G12A DM71K4					28
3.8	605	0.80	373.00		
4.2	540	0.85	332.76		
4.7	485	0.95	298.48		
5.2	440	1.05	271.27		
5.9	390	1.20	239.17		
6.7	345	1.35	211.83		
F33A DM71K4					22
7.4	320	1.45	190.26		
8.6	275	1.70	163.34		
9.9	240	1.95	142.09		
F23G02A DM71K4					19
7.8	295	0.85	181.93		
Type	n2 [1/min]	T2 [Nm]	cG	i	-kg
0.37 kW					
F23A DM71K4					16
8.3	290	0.85	170.20		
9.7	245	1.00	145.41		
11	215	1.15	125.84		
13	186	1.30	109.99		
15	164	1.50	96.90		
16	145	1.70	85.91		
18	131	1.90	77.09		
21	114	2.1	67.38		
24	101	2.4	59.37		
27	89	2.7	52.63		
31	78	3.1	46.08		
35	69	3.6	40.60		
39	61	4.0	35.99		
44	54	4.5	32.07		
49	49	5.0	28.79		
56	43	5.8	25.12		
64	37	6.2	22.01		
F22A DM71K4					16
43	55	4.5	32.42		
51	47	5.2	27.83		
58	41	6.0	24.21		
66	36	6.8	21.28		
75	32	7.7	18.86		
84	28	8.6	16.82		
93	26	9.4	15.09		
103	23	10	13.71		
117	20	11	12.09		
132	18	12	10.71		
185	13	13	7.62		
207	12	14	6.80		
231	10	15	6.10		
254	9.4	15	5.54		
289	8.3	16	4.89		
326	7.3	17	4.33		
F53G22A DM71G4					63
2.9	1190	1.35	494.02		
3.2	1070	1.50	445.85		
3.4	985	1.60	410.38		
3.8	880	1.80	366.79		
4.3	785	2.0	325.70		
F43G12A DM71G4					39
3.3	1030	0.85	426.68		
3.7	930	0.95	386.00		
4.0	845	1.05	351.84		
4.5	755	1.15	313.88		
5.0	675	1.30	281.55		
5.5	615	1.45	255.44		
6.2	545	1.60	226.36		
7.1	480	1.85	199.24		
F43A DM71G4					34
6.0	590	1.50	235.25		
6.9	510	1.75	203.29		
7.9	445	2.00	178.07		
F33G12A DM71G4					28
5.9	575	0.80	239.17		
6.7	510	0.90	211.83		
F33A DM71G4					23
7.4	475	1.00	190.26		
8.6	410	1.15	163.34		
9.9	355	1.30	142.09		
11	315	1.50	124.88		
13	275	1.70	110.67		
14	245	1.90	98.73		
Type	n2 [1/min]	T2 [Nm]	cG	i	-kg
0.55 kW					
F23A DM71G4					17
11	315	0.80	125.84		
13	275	0.90	109.99		
15	245	1.00	96.90		
16	215	1.15	85.91		
18	193	1.25	77.09		
21	169	1.45	67.38		
24	149	1.65	59.37		
27	132	1.85	52.63		
31	115	2.1	46.08		
35	102	2.4	40.60		
39	90	2.7	35.99		
44	80	3.0	32.07		
49	72	3.4	28.79		
56	63	3.9	25.12		
64	55	4.2	22.01		
F22A DM71G4					16
43	81	3.0	32.42		
51	70	3.5	27.83		
58	61	4.0	24.21		
66	53	4.6	21.28		
75	47	5.2	18.86		
84	42	5.8	16.82		
93	38	6.3	15.09		
103	34	6.8	13.71		
117	30	7.4	12.09		
132	27	8.0	10.71		
185	19	8.6	7.62		
207	17	9.4	6.80		
231	15	9.8	6.10		

Type	n2 [1/min]	T2 [Nm]	cG	i	-kg
F23A DM80K4					18
18	290	0.85	77.09		
21	250	0.95	67.38		
24	220	1.10	59.37		
27	197	1.25	52.63		
30	172	1.40	46.08		
35	152	1.60	40.60		
39	135	1.80	35.99		
44	120	2.0	32.07		
49	108	2.3	28.79		
56	94	2.6	25.12		
64	82	2.8	22.01		
F22A DM80K4					18
58	91	2.7	24.21		
66	80	3.1	21.28		
75	70	3.5	18.86		
84	63	3.9	16.82		
93	56	4.3	15.09		
102	51	4.6	13.71		
116	45	5.0	12.09		
131	40	5.4	10.71		
184	28	5.8	7.62		
207	25	6.3	6.80		
230	23	6.6	6.10		
254	21	6.9	5.54		
288	18	7.2	4.89		
325	16	7.5	4.33		
F63G22A DM80GC4					98
3.1	2220	1.25	455.13		
3.5	1990	1.40	407.58		
3.8	1790	1.55	366.82		
4.4	1560	1.80	320.02		
4.9	1400	2.0	286.71		
F53G22A DM80GC4					67
3.4	2000	0.80	410.38		
3.8	1790	0.90	366.79		
4.3	1590	1.00	325.70		
4.9	1410	1.15	288.62		
5.6	1230	1.30	252.64		
6.2	1110	1.40	228.00		
6.7	1020	1.55	209.86		
F53A DM80GC4					58
6.9	1040	1.50	205.64		
7.7	930	1.70	182.73		
8.6	830	1.90	163.81		
F43G12A DM80GC4					42
6.2	1100	0.80	226.36		
7.1	970	0.90	199.24		
F43A DM80GC4					37
7.9	905	1.00	178.07		
8.9	800	1.10	157.64		
10	715	1.25	140.77		
11	645	1.35	126.60		
12	580	1.50	114.53		
14	530	1.65	104.39		
15	475	1.85	93.13		
F33A DM80GC4					26
13	560	0.85	110.67		
14	500	0.95	98.73		
16	450	1.05	88.56		
18	410	1.15	80.49		
20	360	1.30	70.96		
22	320	1.50	62.85		
29	250	1.90	49.17		

0.75 kW

Type	n2 [1/min]	T2 [Nm]	cG	i	-kg
F23A DM80GC4					20
24	300	0.80	59.37		
27	265	0.90	52.63		
31	235	1.05	46.08		
35	205	1.20	40.60		
39	183	1.35	35.99		
44	163	1.50	32.07		
49	146	1.70	28.79		
56	128	1.90	25.12		
64	112	2.1	22.01		
F22A DM80GC4					20
58	123	2.00	24.21		
66	108	2.3	21.28		
75	96	2.6	18.86		
84	85	2.9	16.82		
93	77	3.1	15.09		
103	70	3.4	13.71		
117	61	3.7	12.09		
132	54	4.0	10.71		
185	39	4.3	7.62		
207	35	4.6	6.80		
231	31	4.8	6.10		
254	28	5.0	5.54		
289	25	5.3	4.89		
326	22	5.6	4.33		

1.1 kW

Type	n2 [1/min]	T2 [Nm]	cG	i	-kg
F73G32A DM90SC4					156
3.1	3240	1.50	454.28		
3.7	2750	1.80	385.26		
4.1	2480	1.95	347.80		
4.5	2250	2.2	315.75		
5.0	2010	2.4	281.53		
F73A DM90SC4					143
5.2	2040	2.4	274.23		
F63G22A DM90SC4					101
3.1	3240	0.85	455.13		
3.5	2900	0.95	407.58		
3.9	2610	1.05	366.82		
4.4	2280	1.25	320.02		
4.9	2040	1.35	286.71		
5.6	1810	1.55	254.33		
F63A DM90SC4					93
5.8	1800	1.55	242.53		
6.5	1620	1.75	218.27		
7.2	1470	1.90	197.90		
7.8	1340	2.1	180.55		
8.5	1230	2.3	166.08		
9.4	1110	2.5	149.88		
F53G22A DM90SC4					69
5.6	1800	0.90	252.64		
6.2	1620	0.95	228.00		
6.7	1500	1.05	209.86		
7.2	1400	1.15	196.76		
F53A DM90SC4					61
7.7	1360	1.15	182.73		
8.6	1220	1.30	163.81		
9.6	1100	1.45	147.91		
11	1000	1.60	134.37		
12	910	1.75	122.86		
13	820	1.95	110.24		
14	740	2.1	99.49		
15	680	2.3	91.57		

Type	n2 [1/min]	T2 [Nm]	cG	i	-kg
F43A DM90SC4					40
10	1050	0.85	140.77		
11	940	0.95	126.60		
12	850	1.05	114.53		
14	775	1.15	104.39		
15	690	1.30	93.13		
17	620	1.40	83.54		
19	565	1.55	75.79		
21	500	1.75	67.16		
24	440	2.0	59.12		
27	385	2.3	51.77		
30	350	2.5	46.92		
F33A DM90SC4					29
18	600	0.80	80.49		
20	525	0.90	70.96		
23	465	1.00	62.85		
25	420	1.15	56.24		
29	365	1.30	49.17		
32	325	1.45	43.87		
36	290	1.60	39.35		
40	265	1.75	35.76		
45	235	2.0	31.53		
51	205	2.3	27.93		
57	186	2.5	24.99		

Type	n2 [1/min]	T2 [Nm]	cG	i	-kg
F32A DM90SC4					29
51	205	2.3	27.55		
F23A DM90SC4					23
35	300	0.80	40.60		
39	265	0.90	35.99		
44	240	1.05	32.07		
49	215	1.15	28.79		
56	187	1.30	25.12		
64	163	1.40	22.01		
F22A DM90SC4					22
66	158	1.55	21.28		
75	140	1.75	18.86		
84	125	1.95	16.82		
94	112	2.1	15.09		
103	102	2.3	13.71		
117	90	2.5	12.09		
132	80	2.7	10.71		
148	71	2.9	9.58		
170	62	3.1	8.34		
186	57	2.9	7.62		
208	50	3.2	6.80		
232	45	3.3	6.10		
255	41	3.5	5.54		
290	36	3.6	4.89		
327	32	3.8	4.33		
365	29	4.0	3.87		
420	25	4.2	3.37		

1.5 kW

Type	n2 [1/min]	T2 [Nm]	cG	i	-kg
F83G32A DM90LC4					239
3.0	4590	1.95	470.60		
3.4	4020	2.2	412.22		
3.8	3660	2.4	374.97		
F73G32A DM90LC4					158
3.1	4430	1.10	454.28		
3.7	3760	1.30	385.26		
4.1	3390	1.45	347.80		
4.5	3080	1.60	315.75		
5.0	2750	1.80	281.53		
5.9	2330	2.1	238.76		
F73A DM90LC4					146
5.1	2790	1.75	274.23		
5.7	2530	1.90	249.41		
6.2	2320	2.1	228.27		
6.7	2150	2.3	211.55		
7.4	1950	2.5	191.74		

Type	n2 [1/min]	T2 [Nm]	cG	i	-kg
F63G22A DM90LC4					103
3.8	3580	0.80	366.82		
4.4	3120	0.90	320.02		
4.9	2800	1.00	286.71		
5.5	2480	1.15	254.33		
F63A DM90LC4					96
5.8	2460	1.15	242.53		
6.5	2220	1.25	218.27		
7.1	2010	1.40	197.90		
7.8	1830	1.55	180.55		
8.5	1690	1.65	166.08		
9.4	1520	1.85	149.88		
10	1380	2.0	136.08		
11	1280	2.2	125.81		
12	1150	2.4	113.33		
F53G22A DM90LC4					71
7.2	1920	0.85	196.76		
F53A DM90LC4					63
7.7	1860	0.85	182.73		
8.6	1660	0.95	163.81		
9.5	1500	1.05	147.91		
10	1370	1.15	134.37		
11	1250	1.25	122.86		
13	1120	1.40	110.24		
14	1010	1.55	99.49		
15	930	1.70	91.57		
17	830	1.90	81.85		
19	740	2.1	72.68		
22	655	2.4	64.40		
F43A DM90LC4					42
14	1060	0.85	104.39		
15	945	0.95	93.13		
17	850	1.05	83.54		
19	770	1.15	75.79		
21	680	1.30	67.16		
24	600	1.45	59.12		
27	525	1.70	51.77		
30	475	1.85	46.92		
34	430	2.1	42.08		
37	390	2.3	38.18		
F33A DM90LC4					32
25	570	0.80	56.24		
29	500	0.95	49.1		

Type	n2 [1/min]	T2 [Nm]	cG	i	-kg
F22A DM90LC4					25
66	215	1.15	21.28		
75	192	1.30	18.86		
84	171	1.45	16.82		
93	153	1.55	15.09		
103	139	1.70	13.71		
117	123	1.85	12.09		
132	109	2.00	10.71		
147	97	2.1	9.58		
169	85	2.3	8.34		
185	77	2.1	7.62		
207	69	2.3	6.80		
231	62	2.4	6.10		
254	56	2.5	5.54		
289	50	2.7	4.89		
326	44	2.8	4.33		
364	39	2.9	3.87		
418	34	3.0	3.37		

2.2 kW

Type	n2 [1/min]	T2 [Nm]	cG	i	-kg
F83G32A DM100LC4					246
3.0	6730	1.30	470.60		
3.4	5900	1.50	412.22		
3.8	5360	1.65	374.97		
4.2	4830	1.85	337.74		
4.6	4340	2.1	303.24		
5.4	3720	2.4	260.13		

Type	n2 [1/min]	T2 [Nm]	cG	i	-kg
F73G32A DM100LC4					165
3.7	5510	0.90	385.26		
4.1	4980	1.00	347.80		
4.5	4520	1.10	315.75		
5.0	4030	1.20	281.53		
5.9	3420	1.45	238.76		

Type	n2 [1/min]	T2 [Nm]	cG	i	-kg
F73A DM100LC4					152
5.1	4090	1.20	274.23		
5.7	3720	1.30	249.41		
6.2	3400	1.45	228.27		
6.7	3150	1.55	211.55		
7.4	2860	1.70	191.74		
8.1	2610	1.85	174.87		
8.7	2420	2.0	162.19		
9.6	2190	2.2	146.94		
11	1990	2.4	133.66		

Type	n2 [1/min]	T2 [Nm]	cG	i	-kg
F63A DM100LC4					102
6.5	3250	0.85	218.27		
7.1	2950	0.95	197.90		
7.8	2690	1.05	180.55		
8.5	2470	1.15	166.08		
9.4	2230	1.25	149.88		
10	2030	1.40	136.08		
11	1870	1.50	125.81		
12	1690	1.65	113.33		
14	1510	1.85	101.56		
16	1360	2.1	90.95		
17	1220	2.3	81.85		

Type	n2 [1/min]	T2 [Nm]	cG	i	-kg
F53A DM100LC4					71
10	2000	0.80	134.37		
11	1830	0.85	122.86		
13	1640	0.95	110.24		
14	1480	1.05	99.49		
15	1360	1.15	91.57		
17	1220	1.30	81.85		
19	1080	1.45	72.68		
22	960	1.65	64.40		
25	840	1.90	56.37		
28	760	2.1	50.88		
30	700	2.3	46.83		
34	625	2.5	41.85		

Type	n2 [1/min]	T2 [Nm]	cG	i	-kg
F43A DM100LC4					49
19	1130	0.80	75.79		
21	1000	0.90	67.16		
24	880	1.00	59.12		
27	770	1.15	51.77		
30	700	1.25	46.92		
34	625	1.40	42.08		
37	570	1.55	38.18		
42	505	1.75	33.83		
47	445	2.00	29.78		
54	390	2.2	26.08		
62	340	2.3	22.91		

Type	n2 [1/min]	T2 [Nm]	cG	i	-kg
F42A DM100LC4					49
47	450	1.95	30.05		
52	405	2.2	27.14		
57	365	2.4	24.65		

Type	n2 [1/min]	T2 [Nm]	cG	i	-kg
F33A DM100LC4					39
36	585	0.80	39.35		
39	535	0.90	35.76		
45	470	1.00	31.53		
50	415	1.15	27.93		
56	370	1.25	24.99		
65	325	1.45	21.75		

Type	n2 [1/min]	T2 [Nm]	cG	i	-kg
F32A DM100LC4					38
57	365	1.30	24.60		
64	330	1.45	22.12		
70	300	1.55	20.01		
77	270	1.65	18.24		
87	240	1.80	16.27		
97	220	1.95	14.60		
106	197	2.1	13.24		
120	175	2.3	11.74		
136	154	2.5	10.33		
166	127	1.95	8.50		
186	113	2.1	7.58		
207	101	2.2	6.80		
229	92	2.3	6.17		
258	81	2.5	5.47		

Type	n2 [1/min]	T2 [Nm]	cG	i	-kg
F22A DM100LC4					32
75	280	0.85	18.86		
84	250	1.00	16.82		
93	225	1.05	15.09		
103	205	1.15	13.71		
117	180	1.25	12.09		
132	160	1.35	10.71		
147	143	1.45	9.58		
169	124	1.55	8.34		
185	114	1.45	7.62		
207	101	1.60	6.80		
231	91	1.65	6.10		
254	83	1.70	5.54		
289	73	1.80	4.89		
326	64	1.90	4.33		
364	58	2.00	3.87		
418	50	2.1	3.37		

3.0 kW

Type	n2 [1/min]	T2 [Nm]	cG	i	-kg
F83G32A DM100LD4					250
3.0	9180	0.95	470.60		
3.4	8040	1.10	412.22		
3.8	7310	1.20	374.97		
4.2	6590	1.35	337.74		
4.6	5920	1.50	303.24		
5.4	5070	1.75	260.13		
6.2	4460	2.00	228.49		

Type	n2 [1/min]	T2 [Nm]	cG	i	-kg
F83A DM100LD4					236
7.0	4080	2.2	200.61		
7.7	3730	2.4	183.42		

Type	n2 [1/min]	T2 [Nm]	cG	i	-kg
F73G32A DM100LD4					169
4.5	6160	0.80	315.75		
5.0	5490	0.90	281.53		
5.9	4660	1.05	238.76		

Type	n2 [1/min]	T2 [Nm]	cG	i	-kg
F73A DM100LD4					156
5.1	5570	0.90	274.23		
5.7	5070	0.95	249.41		
6.2	4640	1.05	228.27		
6.7	4300	1.15	211.55		
7.4	3900	1.25	191.74		
8.1	3550	1.35	174.87		
8.7	3300	1.50	162.19		
9.6	2990	1.65	146.94		
11	2720	1.80	133.66		
12	2450	2.00	120.60		
13	2220	2.2	109.41		

Type	n2 [1/min]	T2 [Nm]	cG	i	-kg
F63A DM100LD4					106
8.5	3370	0.85	166.08		
9.4	3050	0.90	149.88		
10	2770	1.00	136.08		
11	2560	1.10	125.81		
12	2300	1.20	113.33		
14	2060	1.35	101.56		
16	1850	1.50	90.95		
17	1660	1.70	81.85		

Type	n2 [1/min]	T2 [Nm]	cG	i	-kg
F53A DM100LD4					74
14	2020	0.80	99.49		
15	1860	0.85	91.57		
17	1660	0.95	81.85		
19	1480	1.05	72.68		
22	1310	1.20	64.40		
25	1150	1.40	56.37		
28	1030	1.55	50.88		
30	950	1.65	46.83		
34	850	1.85	41.85		
38	755	2.1	37.17		
43	670	2.4	32.93		

Type	n2 [1/min]	T2 [Nm]	cG	i	-kg
F52A DM100LD4					72
41	700	2.1	34.34		
45	635	2.3	31.33		

Type	n2 [1/min]	T2 [Nm]	cG	i	-kg
F43A DM100LD4					53
27	1050	0.85	51.77		
30	955	0.95	46.92		
34	855	1.05	42.08		
37	775	1.15	38.18		
42	685	1.30	33.83		
47	605	1.45	29.78		
54	530	1.60	26.08		
62	465	1.70	22.91		

Type	n2 [1/min]	T2 [Nm]	cG	i	-kg
F42A DM100LD4					52
47	610	1.45	30.05		
52	550	1.60	27.14		
57	500	1.75	24.65		
63	460	1.95	22.54		
70	410	2.1	20.22		
77	370	2.4	18.25		

Type	n2 [1/min]	T2 [Nm]	cG	i	-kg
F33A DM100LD4					42
50	565	0.85	27.93		
56	510	0.95	24.99		
65	440	1.05	21.75		

Type	n2 [1/min]	T2 [Nm]	cG	i	-kg
F32A DM100LD4					42
57	500	0.95	24.60		
64	450	1.05	22.12		
70	405	1.15	20.01		
77	370	1.20	18.24		
87	330	1.30	16.27		
97	295	1.45	14.60		
106	270	1.55	13.24		
120	240	1.70	11.74		
136	210	1.85	10.33		
156	184	2.0	9.05		
166	173	1.4			

Type	n2 [1/min]	T2 [Nm]	cG	i	-kg
F53A DM112MX4					82
20	1950	0.80	72.68		
22	1730	0.90	64.40		
25	1510	1.05	56.37		
28	1360	1.15	50.88		
30	1260	1.25	46.83		
34	1120	1.40	41.85		
38	995	1.60	37.17		
43	885	1.80	32.93		
49	785	2.0	29.31		
F52A DM112MX4					81
41	920	1.60	34.34		
45	840	1.70	31.33		
49	775	2.1	28.82		
55	695	2.3	26.01		
60	635	2.5	23.61		
F43A DM112MX4					61
34	1130	0.80	42.08		
37	1020	0.85	38.18		
42	905	0.95	33.83		
48	800	1.10	29.78		
55	700	1.20	26.08		
62	615	1.30	22.91		
F42A DM112MX4					61
53	725	1.20	27.14		
58	660	1.35	24.65		
63	605	1.45	22.54		
70	540	1.65	20.22		
78	490	1.80	18.25		
85	450	1.95	16.80		
95	405	2.2	15.02		
107	355	2.5	13.33		
194	197	2.2	7.36		
F33A DM112MX4					51
66	585	0.80	21.75		
F32A DM112MX4					50
64	595	0.80	22.12		
71	535	0.85	20.01		
78	490	0.90	18.24		
88	435	1.00	16.27		
98	390	1.10	14.60		
108	355	1.15	13.24		
121	315	1.25	11.74		
138	275	1.40	10.33		
158	245	1.55	9.05		
168	230	1.10	8.50		
179	215	1.70	7.95		
188	205	1.15	7.58		
210	182	1.25	6.80		
231	165	1.30	6.17		
261	147	1.40	5.47		
296	129	1.50	4.81		
338	113	1.60	4.21		
385	99	1.70	3.70		

5.5 kW

Type	n2 [1/min]	T2 [Nm]	cG	i	-kg
F83G32A DA132S4					276
4.8	10500	0.85	303.24		
5.6	9010	1.00	260.13		
6.4	7920	1.10	228.49		
F83A DA132S4					264
7.3	7240	1.25	200.61		
7.9	6620	1.35	183.42		
8.6	6120	1.45	169.54		
9.4	5560	1.60	154.08		
10	5080	1.75	140.63		
11	4600	1.95	127.39		
13	4190	2.1	116.03		
14	3670	2.4	101.64		

Type	n2 [1/min]	T2 [Nm]	cG	i	-kg
F73A DA132S4					183
9.0	5850	0.85	162.19		
9.9	5300	0.90	146.94		
11	4820	1.00	133.66		
12	4350	1.10	120.60		
13	3950	1.25	109.41		
15	3420	1.45	94.78		
17	3100	1.60	85.76		
19	2810	1.75	77.85		
21	2510	1.95	69.41		
25	2130	2.3	58.87		
F63A DA132S4					133
16	3280	0.85	90.95		
18	2950	0.95	81.85		
20	2580	1.10	71.41		
23	2310	1.20	63.98		
26	2050	1.35	56.75		
30	1780	1.55	49.31		
33	1590	1.75	44.16		
37	1430	1.95	39.74		
42	1250	2.2	34.67		
47	1120	2.5	31.06		
F62A DA132S4					131
43	1230	2.1	34.05		
47	1120	2.2	31.05		
F53A DA132S4					101
26	2040	0.80	56.37		
29	1840	0.85	50.88		
31	1690	0.95	46.83		
35	1510	1.05	41.85		
39	1340	1.20	37.17		
44	1190	1.35	32.93		
50	1060	1.50	29.31		
58	905	1.75	25.11		
66	800	1.85	22.15		
F52A DA132S4					100
56	940	1.70	26.01		
62	850	1.85	23.61		
67	790	2.0	21.83		
74	710	2.2	19.67		
83	635	2.5	17.62		
F43A DA132S4					80
49	1080	0.80	29.78		
56	940	0.90	26.08		
64	825	0.95	22.91		
F42A DA132S4					80
72	730	1.20	20.22		
80	660	1.35	18.25		
87	605	1.45	16.80		
97	540	1.65	15.02		
109	480	1.85	13.33		
123	425	2.1	11.82		
138	380	2.3	10.51		
162	325	2.7	9.01		
183	285	3.1	7.94		
198	265	1.65	7.36		
215	245	2.3	6.77		
240	220	2.5	6.05		
271	194	2.9	5.38		
305	172	3.1	4.76		
343	153	3.3	4.24		
401	131	3.6	3.63		
454	116	3.8	3.20		

7.5 kW

Type	n2 [1/min]	T2 [Nm]	cG	i	-kg
F83G32A DA132MX4					290
6.4	10800	0.80	228.49		

Type	n2 [1/min]	T2 [Nm]	cG	i	-kg
F83A DA132MX4					277
7.3	9880	0.90	200.61		
7.9	9030	1.00	183.42		
8.6	8350	1.05	169.54		
9.4	7580	1.15	154.08		
10	6920	1.30	140.63		
11	6270	1.40	127.39		
13	5710	1.55	116.03		
14	5000	1.80	101.64		
16	4550	1.95	92.45		
17	4100	2.2	83.27		
19	3680	2.4	74.77		
F73A DA132MX4					197
12	5940	0.80	120.60		
13	5390	0.90	109.41		
15	4670	1.05	94.78		
17	4220	1.15	85.76		
19	3830	1.25	77.85		
21	3420	1.45	69.41		
25	2900	1.70	58.87		
28	2550	1.90	51.81		
32	2210	2.2	44.88		
36	2000	2.4	40.61		
F63A DA132MX4					146
20	3520	0.80	71.41		
23	3150	0.90	63.98		
26	2790	1.00	56.75		
30	2430	1.15	49.31		
33	2170	1.30	44.16		
37	1960	1.45	39.74		
42	1710	1.65	34.67		
47	1530	1.80	31.06		
53	1360	1.90	27.56		
60	1190	2.0	24.21		
F62A DA132MX4					144
43	1680	1.50	34.05		
47	1530	1.65	31.05		
51	1420	2.00	28.80		
56	1280	2.2	26.09		
61	1170	2.4	23.73		
F53A DA132MX4					115
39	1830	0.85	37.17		
44	1620	1.00	32.93		
50	1440	1.10	29.31		
58	1240	1.30	25.11		
66	1090	1.35	22.15		
F52A DA132MX4					114
56	1280	1.25	26.01		
62	1160	1.35	23.61		
67	1070	1.45	21.83		
74	970	1.65	19.67		
83	865	1.85	17.62		
92	775	2.0	15.78		
102	700	2.3	14.20		
188	380	2.4	7.74		
F42A DA132MX4					93
72	995	0.90	20.22		
80	900	1.00	18.25		
87	825	1.05	16.80		
97	740	1.20	15.02		
109	655	1.35	13.33		
123	580	1.50	11.82		
138	520	1.70	10.51		
162	445	2.00	9.01		
183	390	2.3	7.94		
198	360	1.20	7.36		
215	335	1.70	6.77		
240	300	1.85	6.05		
271	265	2.1	5.38		
305	235	2.3	4.76		
343	210	2.4	4.24		
401	179	2.6	3.63		
454	158	2.8	3.20		

9.2 kW

Type	n2 [1/min]	T2 [Nm]	cG	i	-kg
F83A DA160MS4					292
9.5	9210	0.95	154.08		
10	8410	1.05	140.63		
12	7610	1.15	127.39		
13	6940	1.30	116.03		
14	6070	1.45	101.64		
16	5530	1.60	92.45		
18	4980	1.80	83.27		
20	4470	2.00	74.77		
23	3830	2.3	64.14		
F73A DA160MS4					211
16	5660	0.85	94.78		
17	5130	0.95	85.76		
19	4650	1.05	77.85		
21	4150	1.20	69.41		
25	3520	1.40	58.87		
28	3100	1.55	51.81		
33	2680	1.80	44.88		
36	2430	2.00	40.61		
40	2200	2.1	36.86		
45	1960	2.2	32.87		
53	1670	2.5	27.88		
F63A DA160MS4					162
26	3390	0.85	56.75		
30	2950	0.95	49.31		
33	2640	1.05	44.16		
37	2380	1.20	39.74		
42	2070	1.35	34.67		
47	1860	1.50	31.06		
53	1650	1.55	27.56		
61	1450	1.65	24.21		
F62A DA160MS4					160
56	1560	1.80	26.09		
62					

Type	n2 [1/min]	T2 [Nm]	cG	i	-kg
F73A DA160M4 216					
17	6150	0.80	85.76		
19	5580	0.85	77.85		
21	4980	1.00	69.41		
25	4220	1.15	58.87		
28	3720	1.30	51.81		
33	3220	1.50	44.88		
36	2910	1.65	40.61		
40	2640	1.75	36.86		
45	2360	1.85	32.87		
53	2000	2.1	27.88		
62	1710	2.2	23.79		
F72A DA160M4 212					
51	2050	2.2	28.53		
57	1850	2.3	25.85		
62	1690	2.5	23.54		
F63A DA160M4 166					
30	3540	0.80	49.31		
33	3170	0.90	44.16		
37	2850	1.00	39.74		
42	2490	1.15	34.67		
47	2230	1.25	31.06		
53	1980	1.30	27.56		
61	1740	1.40	24.21		
F62A DA160M4 164					
56	1870	1.50	26.09		
62	1700	1.65	23.73		
68	1540	1.85	21.42		
75	1390	2.00	19.43		
87	1210	2.2	16.83		
96	1090	2.4	15.23		
106	990	2.5	13.82		
F53A DA160M4 135					
58	1800	0.90	25.11		
66	1590	0.95	22.15		
F52A DA160M4 134					
74	1410	1.10	19.67		
83	1260	1.25	17.62		
93	1130	1.40	15.78		
103	1020	1.55	14.20		
118	890	1.80	12.39		
132	795	1.90	11.10		
149	705	2.1	9.85		
169	620	2.3	8.65		
189	555	1.65	7.74		
211	495	1.75	6.94		
235	450	1.85	6.24		
269	390	2.0	5.45		
300	350	2.1	4.88		
339	310	2.3	4.33		
385	275	2.4	3.80		
15.0 kW					
F83A DA160L4 313					
13	11300	0.80	116.03		
14	9940	0.90	101.64		
16	9040	1.00	92.45		
18	8140	1.10	83.27		
20	7310	1.20	74.77		
23	6270	1.40	64.14		
26	5420	1.65	55.44		
35	4050	2.1	41.43		
39	3640	2.3	37.20		
46	3120	2.5	31.91		
F73A DA160L4 232					
25	5760	0.85	58.87		
28	5070	0.95	51.81		
33	4390	1.10	44.88		
36	3970	1.20	40.61		
40	3600	1.30	36.86		
45	3210	1.35	32.87		
53	2730	1.50	27.88		
62	2330	1.65	23.79		

Type	n2 [1/min]	T2 [Nm]	cG	i	-kg
F72A DA160L4 228					
51	2790	1.60	28.53		
57	2530	1.70	25.85		
62	2300	1.80	23.54		
71	2020	2.00	20.62		
78	1830	2.1	18.76		
87	1650	2.3	16.90		
97	1480	2.5	15.17		
161	890	2.5	9.11		
F63A DA160L4 183					
42	3390	0.85	34.67		
47	3040	0.90	31.06		
53	2690	0.95	27.56		
61	2370	1.00	24.21		
F62A DA160L4 181					
56	2550	1.10	26.09		
62	2320	1.20	23.73		
68	2090	1.35	21.42		
75	1900	1.45	19.43		
87	1650	1.60	16.83		
96	1490	1.75	15.23		
106	1350	1.85	13.82		
119	1210	2.0	12.33		
140	1020	2.3	10.45		
190	755	1.90	7.70		
210	680	2.1	6.97		
232	620	2.2	6.33		
260	550	2.3	5.64		
F52A DA160L4 150					
74	1920	0.80	19.67		
83	1720	0.90	17.62		
93	1540	1.05	15.78		
103	1390	1.15	14.20		
118	1210	1.30	12.39		
132	1090	1.40	11.10		
149	965	1.55	9.85		
169	845	1.70	8.65		
189	755	1.20	7.74		
211	680	1.30	6.94		
235	610	1.35	6.24		
269	530	1.45	5.45		
300	475	1.55	4.88		
339	425	1.70	4.33		
385	370	1.80	3.80		

18.5 kW

F83A DA180MC4 318					
16	11100	0.80	92.45		
18	10000	0.90	83.27		
20	9020	1.00	74.77		
23	7730	1.15	64.14		
26	6690	1.35	55.44		
30	5810	1.50	48.19		
35	5000	1.70	41.43		
39	4490	1.85	37.20		
46	3850	2.1	31.91		
53	3330	2.3	27.58		
61	2890	2.5	23.97		
F73A DA180MC4 237					
28	6250	0.80	51.81		
33	5410	0.90	44.88		
36	4900	1.00	40.61		
40	4450	1.05	36.86		
45	3960	1.10	32.87		
53	3360	1.20	27.88		
62	2870	1.35	23.79		

Type	n2 [1/min]	T2 [Nm]	cG	i	-kg
F72A DA180MC4 233					
57	3120	1.40	25.85		
62	2840	1.50	23.54		
71	2490	1.60	20.62		
78	2260	1.75	18.76		
87	2040	1.85	16.90		
97	1830	2.0	15.17		
113	1570	2.2	13.01		
130	1360	2.5	11.25		
161	1100	2.0	9.11		
177	1000	2.2	8.29		
196	900	2.3	7.46		
219	810	2.4	6.70		
F63A DA180MC4 188					
53	3320	0.80	27.56		
61	2920	0.80	24.21		
F62A DA180MC4 186					
68	2580	1.10	21.42		
75	2340	1.20	19.43		
87	2030	1.30	16.83		
96	1840	1.40	15.23		
106	1670	1.50	13.82		
119	1490	1.65	12.33		
140	1260	1.85	10.45		
164	1080	2.1	8.92		
190	930	1.55	7.70		
210	840	1.65	6.97		
232	765	1.75	6.33		
260	680	1.90	5.64		
306	575	2.1	4.78		
359	490	2.2	4.08		

22.0 kW

F83A DA180LC4 328					
20	10700	0.85	74.77		
23	9200	0.95	64.14		
26	7950	1.10	55.44		
30	6910	1.30	48.19		
35	5940	1.45	41.43		
39	5330	1.55	37.20		
46	4580	1.70	31.91		
53	3960	1.90	27.58		
61	3440	2.1	23.97		
F82A DA180LC4 322					
73	2900	2.2	20.19		
80	2620	2.4	18.25		
F73A DA180LC4 248					
36	5820	0.85	40.61		
40	5290	0.90	36.86		
45	4710	0.95	32.87		
53	4000	1.05	27.88		
62	3410	1.10	23.79		
F72A DA180LC4 244					
57	3710	1.15	25.85		
62	3380	1.25	23.54		
71	2960	1.35	20.62		
78	2690	1.45	18.76		
87	2420	1.55	16.90		
97	2180	1.70	15.17		
113	1870	1.90	13.01		
130	1610	2.1	11.25		
150	1400	2.3	9.78		
161	1310	1.70	9.11		
177	1190	1.80	8.29		
196	1070	1.95	7.46		
219	960	2.1	6.70		
255	825	2.3	5.75		
295	715	2.4	4.97		

Type	n2 [1/min]	T2 [Nm]	cG	i	-kg
F62A DA180LC4 197					
68	3070	0.90	21.42		
75	2790	1.00	19.43		
87	2410	1.10	16.83		
96	2180	1.20	15.23		
106	1980	1.25	13.82		
119	1770	1.35	12.33		
140	1500	1.55	10.45		
164	1280	1.75	8.92		
190	1100	1.30	7.70		
210	1000	1.40	6.97		
232	905	1.50	6.33		
260	810	1.60	5.64		
306	685	1.75	4.78		
359	585	1.90	4.08		

30.0 kW

F83A DA200L4 400					
27	10700	0.85	55.44		
31	9330	0.95	48.19		
36	8020	1.05	41.43		
40	7200	1.15	37.20		
46	6180	1.30	31.91		
54	5340	1.40	27.58		
62	4640	1.55	23.97		
F82A DA200L4 393					
73	3910	1.65	20.19		
81	3530	1.80	18.25		
93	3070	1.95	15.83		
107	2680	2.2	13.85		
121	2360	2.4	12.20		
147	1950	1.95	10.08		
162	1760	2.1	9.11		
187	1530	2.3	7.90		
214	1340	2.4	6.92		
F73A DA200L4 320					
62	4610	0.85	23.79		
F72A DA200L4 316					
72	3990	1.00	20.62		
79	3630	1.10	18.76		
88	3270	1.15	16.90		
98	2940	1.25	15.17		
114	2520	1.40	13.01		
132	2180	1.55	11.25		
151	1890	1.70	9.78		
162	1760	1.25	9.11		
179	1600	1.35	8.29		
198	1450	1.45	7.46		
221	1300	1.55	6.70		
257	1110	1.65	5.75		
298	960	1.80	4.97		

Type				-kg
n2 [1/min]	T2 [Nm]	cG	i	

45.0 kW

F83A DA225MX4 488

46 9300 0.85 31.91

53 8040 0.95 27.58

62 6980 1.05 23.97

F82A DA225MX4 483

73 5880 1.10 20.19

81 5320 1.20 18.25

93 4610 1.30 15.83

106 4040 1.45 13.85

121 3560 1.55 12.20

146 2940 1.30 10.08

162 2650 1.35 9.11

187 2300 1.50 7.90

213 2020 1.60 6.92

242 1780 1.75 6.09

Dimensions

A - Montage flottant

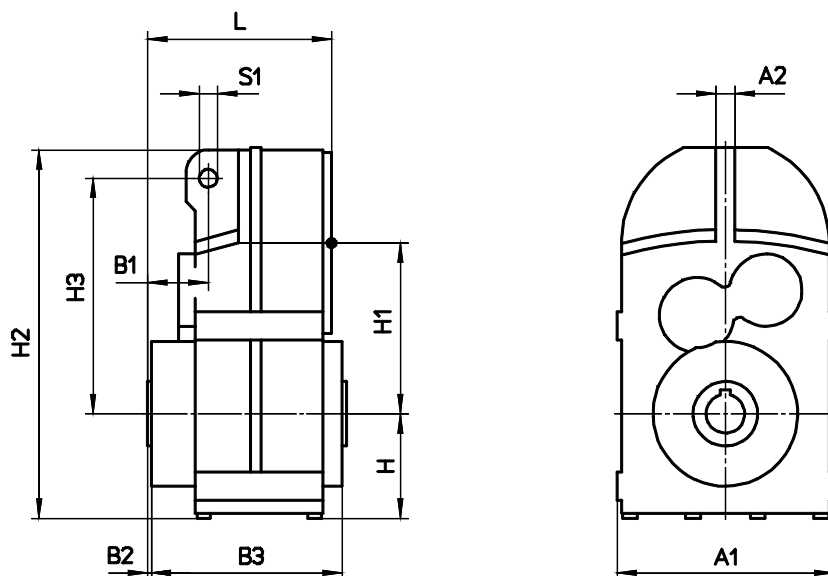

	A1	A2	B1	B2	B3	H	H1	H2	H3	L	S1
F2	150	12	40	1	119	70.5	110	243	156	109	Ø14
F3	168	15	45	1	148	81	132	286.5	182	140.5	Ø14
F4	210	20	47.5	1.5	172	98.5	159	341	217	158.5	Ø14
F5	263	25	53	1.5	207	120.5	196	421	270	184	Ø22
F6	313	30	62	2.5	235	144.5	234	508	328	215	Ø22
F7	367	35	76	3.5	293	171.5	273	599.5	382	250.5	Ø26
F8	417	40	93	3.5	343	191.5	324	696.5	458	301	Ø26

B - Montage flottant

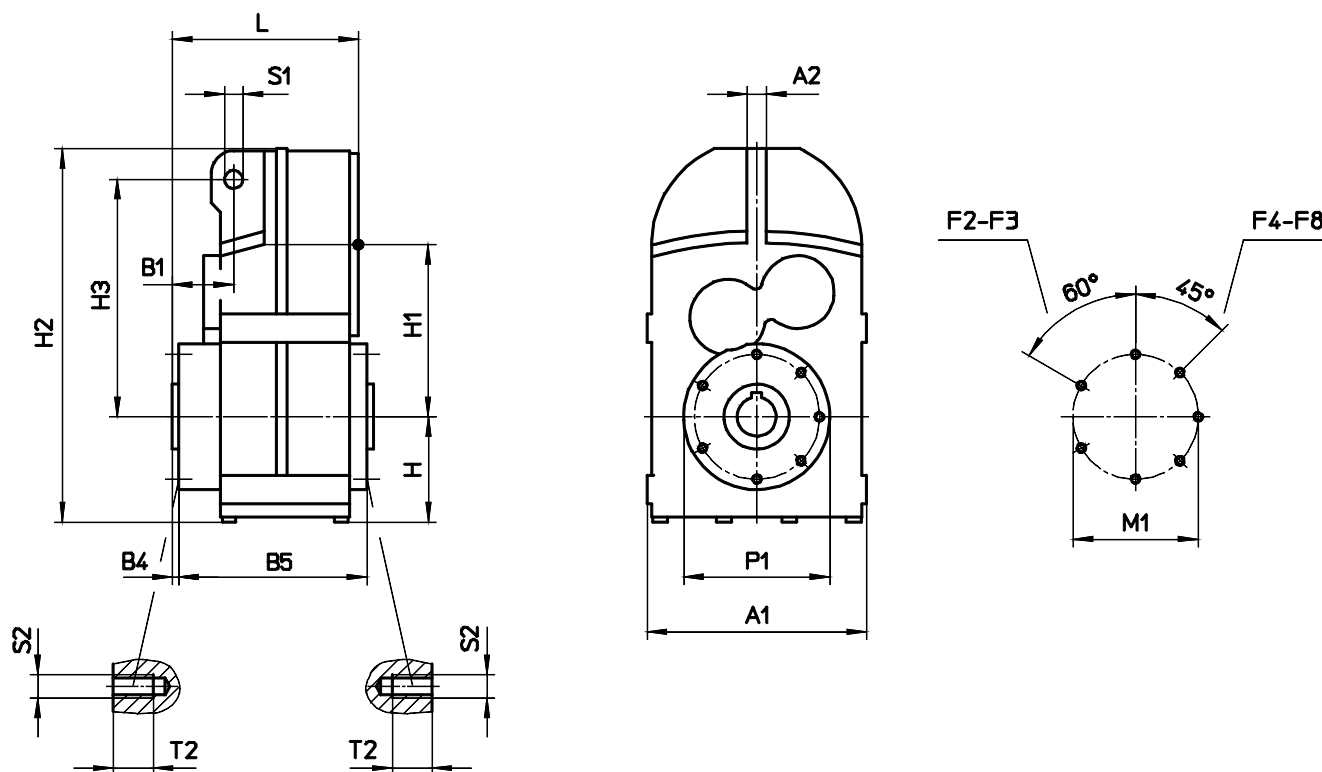

	A1	A2	B1	B4	B5	H	H1	H2	H3	L	S1	M1	P1	S2	T2
F2	150	12	40	2	116	70.5	110	243	156	109	∅14	87	99	M6	9
F3	168	15	45	3	144	81	132	286.5	182	140.5	∅14	96	112	M8	12
F4	210	20	47.5	3.5	168	98.5	159	341	217	158.5	∅14	106	122	M8	12
F5	263	25	53	4	202	120.5	196	421	270	184	∅22	130	150	M10	15
F6	313	30	62	5	230	144.5	234	508	328	215	∅22	154	178	M12	18
F7	367	35	76	6	288	171.5	273	599.5	382	250.5	∅26	182	214	M16	24
F8	417	40	93	6	338	191.5	324	696.5	458	301	∅26	220	260	M20	30

C - Version à bride

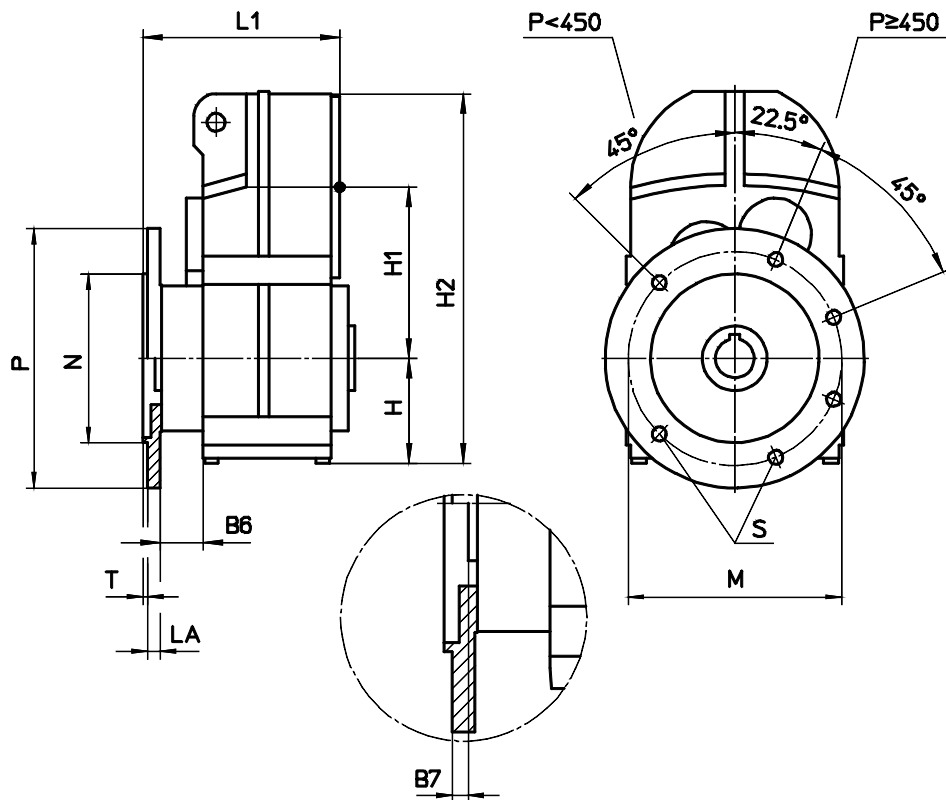

	B6	B7	H	H1	H2	L1
F2	26	10	70.5	110	243	122.5
F3	33	8	81	132	286.5	152
F4	34	7.5	98.5	159	341	169.5
F5	42	8	120.5	196	421	196
F6	46	8	144.5	234	508	227
F7	55.5	10	171.5	273	599.5	265.5
F8	60	15	191.5	324	696.5	321

	M	N	P	LA	T	S
F2	Ø130	Ø110 j6	Ø160	9	3.5	Ø9
F3	Ø130	Ø110 j6	Ø160	9	3.5	Ø9
	Ø165	Ø130 j6	Ø200	10	3.5	Ø11
F4	Ø165	Ø130 j6	Ø200	10	3.5	Ø11
	Ø215	Ø180 j6	Ø250	11	4	Ø13.5
F5	Ø215	Ø180 j6	Ø250	11	4	Ø13.5
	Ø265	Ø230 j6	Ø300	12	4	Ø13.5
F6	Ø265	Ø230 j6	Ø300	12	4	Ø13.5
	Ø300	Ø250 h6	Ø350	13	5	Ø17.5
F7	Ø300	Ø250 h6	Ø350	13	5	Ø17.5
	Ø400	Ø350 h6	Ø450	16	5	Ø17.5
F8	Ø400	Ø350 h6	Ø450	16	5	Ø17.5

D - Exécution montage flottant + faces latérales

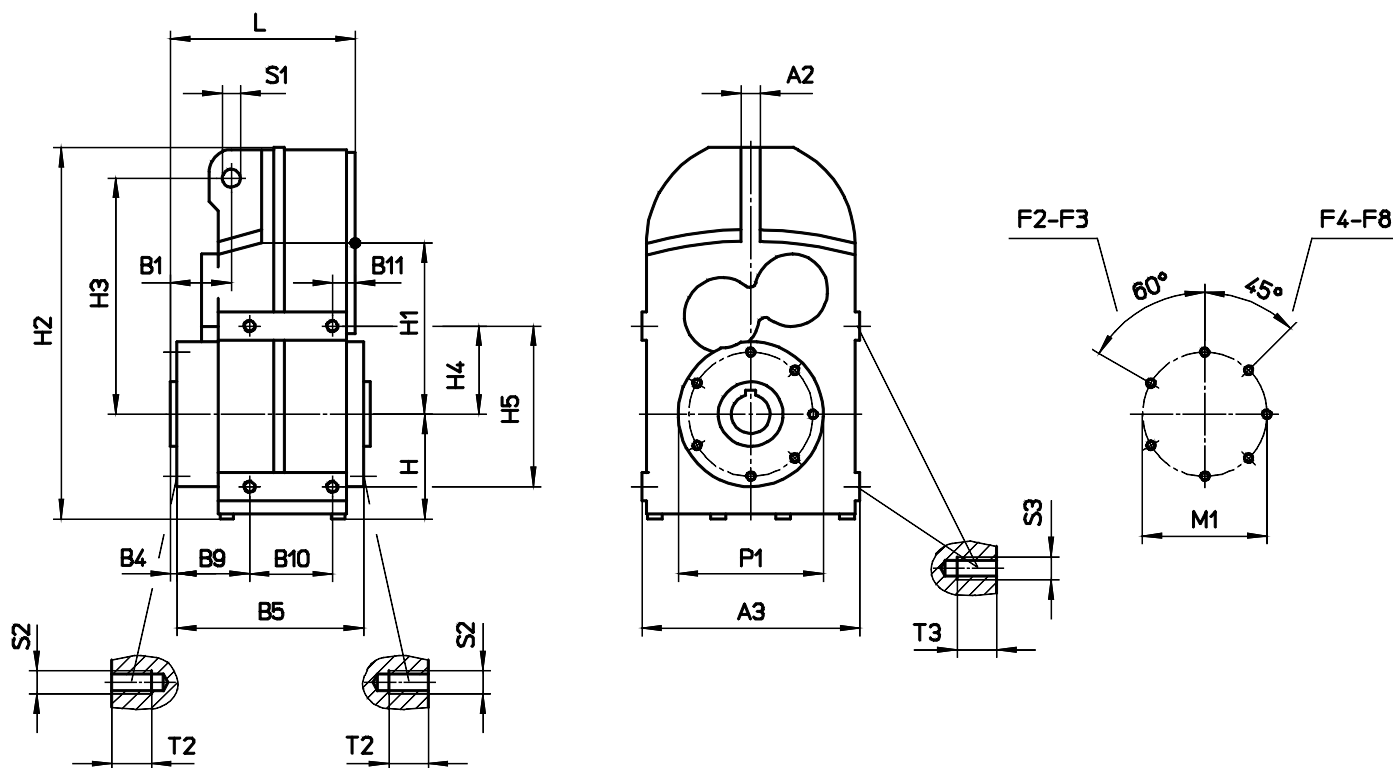

	A2	A3	B1	B4	B5	B9	B10	B11	H	H1	H2	H3	H4	H5	L	S1	M1	P1	S2	T2	S3	T3
F2	12	146	40	2	116	31	64	12	70.5	110	243	156	55	100	109	Ø14	87	99	M6	9	M8	12
F3	15	164	45	3	144	56	64	17.5	81	132	286.5	182	68	124	140.5	Ø14	96	112	M8	12	M10	15
F4	20	206	47.5	3.5	168	57	80	18	98.5	159	341	217	87	158	158.5	Ø14	106	122	M8	12	M12	18
F5	25	258	53	4	202	60	104	16	120.5	196	421	270	112	202	184	Ø22	130	150	M10	15	M12	18
F6	30	308	62	5	230	70	120	20	144.5	234	508	328	134	244	215	Ø22	154	178	M12	18	M16	24
F7	35	362	76	6	288	75.5	145	24	171.5	273	599.5	382	245	370	250.5	Ø26	182	214	M16	24	M20	30
F8	40	412	93	6	338	81	185	29	191.5	324	696.5	458	298	440	301	Ø26	220	260	M20	30	M24	36

E - Exécution à bride + faces latérales

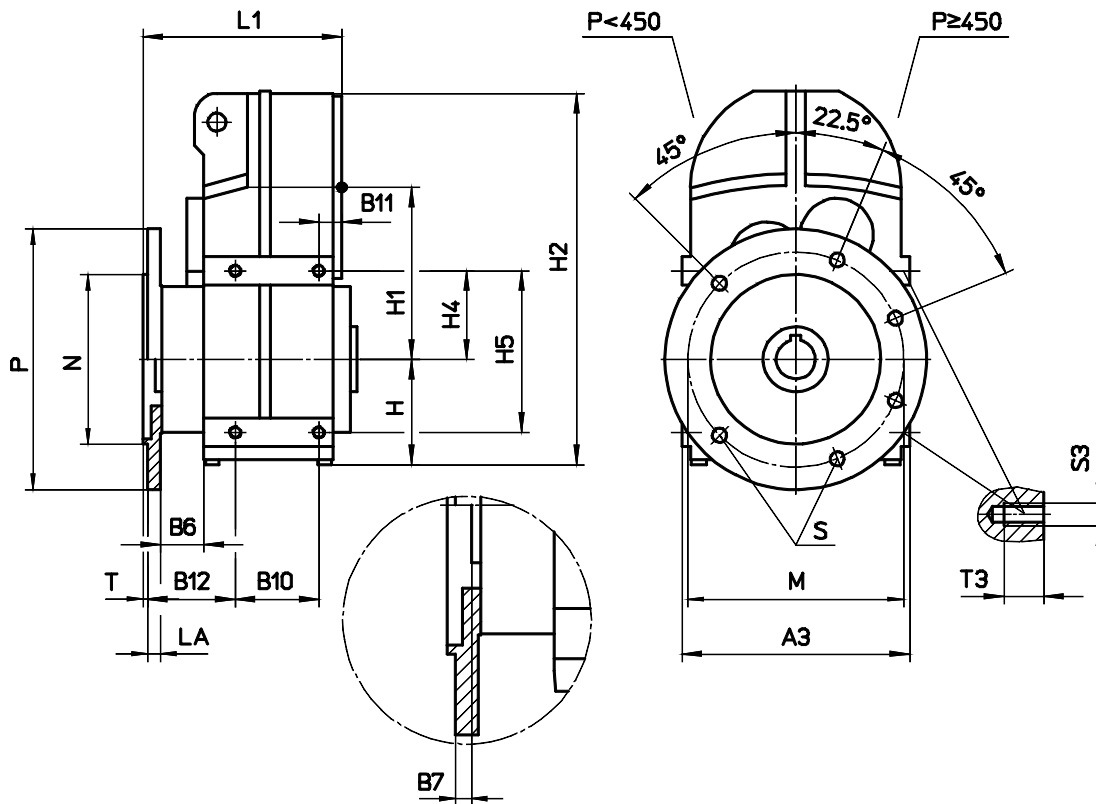

	A3	B6	B7	B10	B11	B12	H	H1	H2	H4	H5	L1	S3	T3
F2	146	26	10	64	12	43	70.5	110	243	55	100	122.5	M8	12
F3	164	33	8	64	17.5	67	81	132	286.5	68	124	152	M10	15
F4	206	34	7.5	80	18	68	98.5	159	341	87	158	169.5	M12	18
F5	258	42	8	104	16	72	120.5	196	421	112	202	196	M12	18
F6	308	46	8	120	20	83	144.5	234	508	134	244	227	M16	24
F7	362	55.5	10	145	24	91.5	171.5	273	599.5	245	370	265.5	M20	30
F8	412	60	15	185	29	102	191.5	324	696.5	298	440	321	M24	36

	M	N	P	LA	T	S
F2	Ø130	Ø110 j6	Ø160	9	3.5	Ø9
F3	Ø130	Ø110 j6	Ø160	9	3.5	Ø9
	Ø165	Ø130 j6	Ø200	10	3.5	Ø11
F4	Ø165	Ø130 j6	Ø200	10	3.5	Ø11
	Ø215	Ø180 j6	Ø250	11	4	Ø13.5
F5	Ø215	Ø180 j6	Ø250	11	4	Ø13.5
	Ø265	Ø230 j6	Ø300	12	4	Ø13.5
F6	Ø265	Ø230 j6	Ø300	12	4	Ø13.5
	Ø300	Ø250 h6	Ø350	13	5	Ø17.5
F7	Ø300	Ø250 h6	Ø350	13	5	Ø17.5
	Ø400	Ø350 h6	Ø450	16	5	Ø17.5
F8	Ø400	Ø350 h6	Ø450	16	5	Ø17.5

Arbre creux avec rainure de clavette

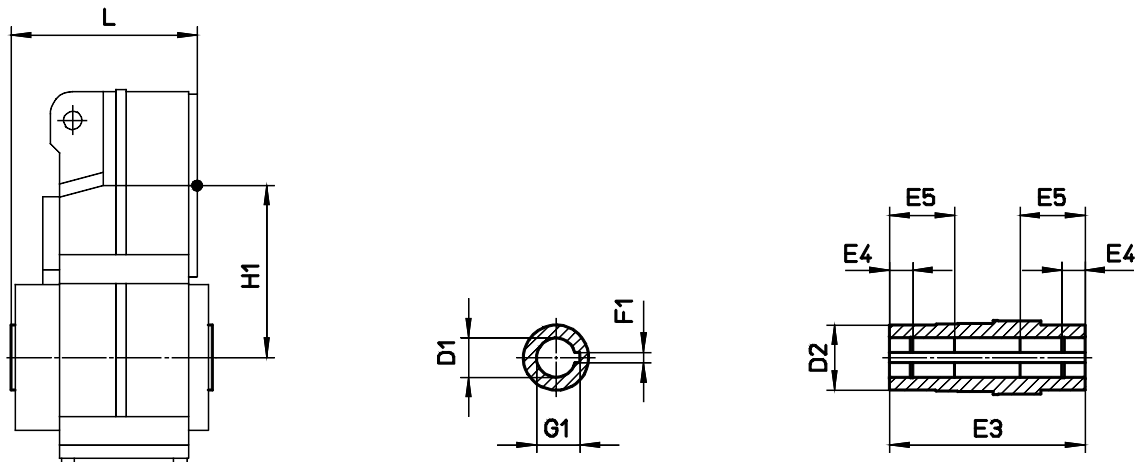

	D1	D2	E3	E4	E5	F1	G1	H1	L
F2	Ø25H7	45	120	15	-	8	28.3	110	109
F3	Ø30H7 Ø35H7	50	150	18	-	8 10	33.3 38.3	132	140.5
F4	Ø40H7	55	175	20	-	12	43.3	159	158.5
F5	Ø50H7	70	210	25	70	14	53.8	196	184
F6	Ø60H7	85	240	30	80	18	64.4	234	215
F7	Ø70H7	100	300	30	100	20	74.9	273	250.5
F8	Ø90H7	120	350	35	120	25	95.4	324	301

V - Arbre de sortie avec clavette

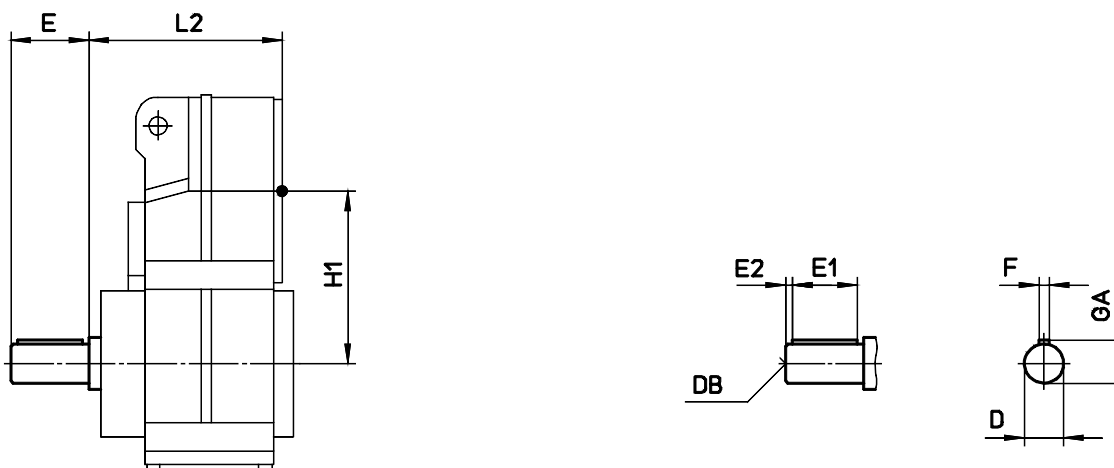

	D	DB	E	E1	E2	F	GA	H1	L2
F2	Ø25k6	M10	50	40	5	8	28	110	119
F3	Ø30k6 Ø35k6	M10 M12	60 70	50 60	5	8 10	33 38	132	148.5
F4	Ø40k6	M16	80	70	5	12	43	159	166
F5	Ø50k6	M16	100	80	10	14	53.5	196	192
F6	Ø60m6	M20	120	100	10	18	64	234	223
F7	Ø75m6	M20	140	125	7.5	20	79.5	273	260.5
F8	Ø90m6	M24	170	140	15	25	95	324	316

S - Arbre creux avec frette de serrage

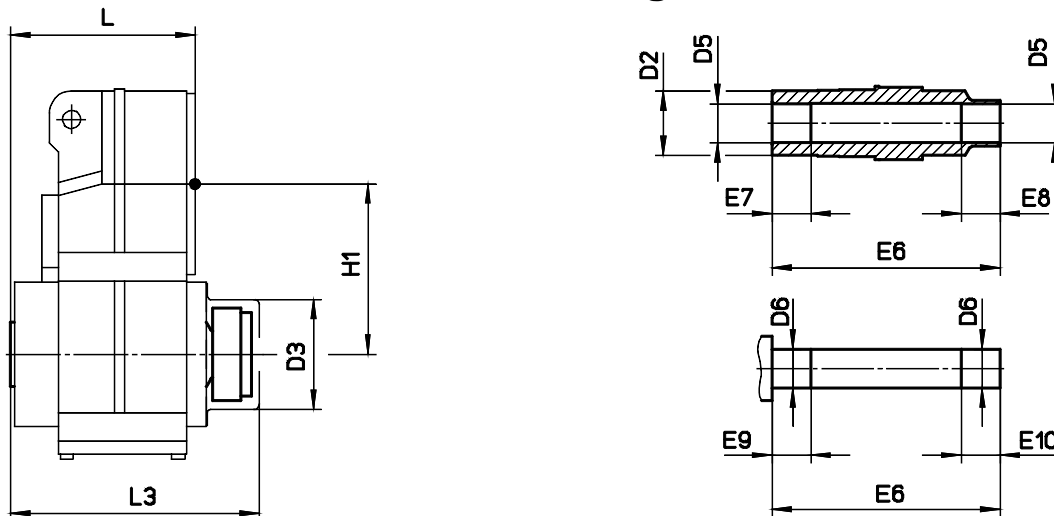

*)		D2	D3	D5	D6	E6	E7	E8	E9	E10	H1	L	L3
F2	DM80 (DM100)	45	77	Ø25H7	Ø25h6	143	25	25	27	27	110	109	158
F3	DM100 (DM112)	50	86	Ø30H7 Ø35H7	Ø30h6 Ø35h6	176	20	30	22	32	132	140.5	188
F4	DM112 (DA132)	55	96	Ø40H7	Ø40h6	202	20	40	22	42	159	158.5	214.5
F5	DA132	70	117	Ø50H7	Ø50h6	242	30	50	32	52	196	184	255
F6	DA180	85	148	Ø60H7	Ø60h6	274	40	60	42	62	234	215	292
F7	DA200	100	180	Ø70H7	Ø70h6	343	50	70	52	72	273	250.5	359
F8	DA225	120	225	Ø95H7	Ø95h6	402	60	80	62	82	324	301	422

*) Taille maxi possible du moteur à monter (sans couvercle de protection)

Z - Arbre creux cannelé

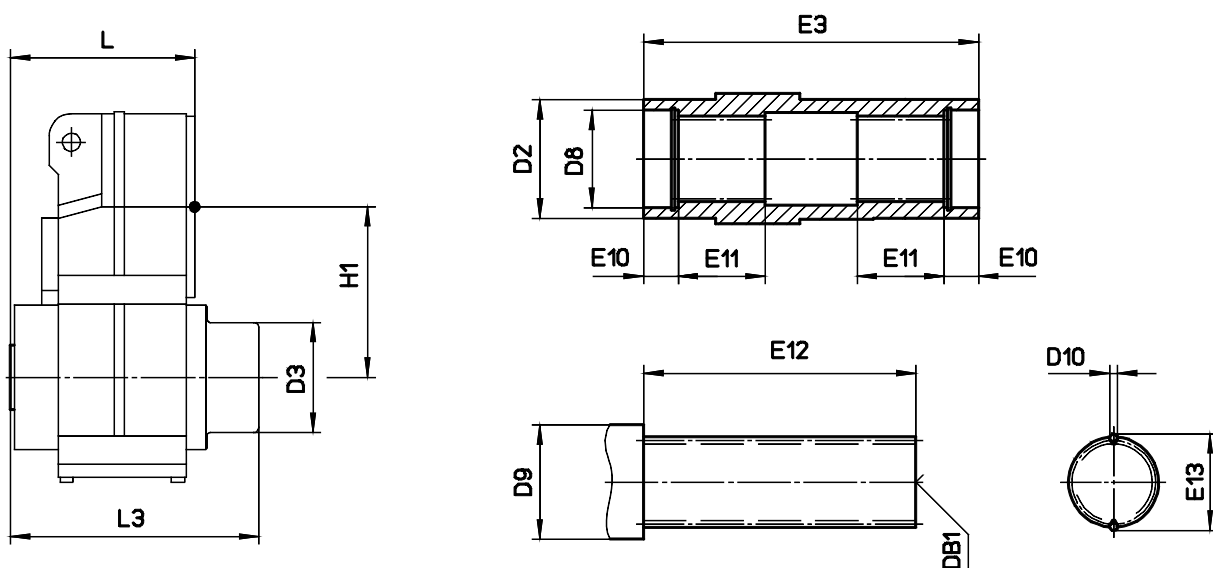

DIN5480		D2	D3	D8	D9	D10	DB1	E3	E10	E11	E12	E13	H1	L	L3
F2	30x1.25x30x22	45	77	35	40	2.75	M10	120	18	25	88	33.05 _{-0.04}	110	109	157
F3	35x2x30x16	50	86	40	46	4	M12	150	18	32	118	38.94 _{-0.04}	132	140.5	188
F4	40x2x30x18	55	96	42	50	4.5	M16	175	23	42	140	45.08 _{-0.04}	159	158.5	214.5
F5	50x2x30x24	70	117	52	62	4	M16	210	23	52	174	54.16 _{-0.05}	196	184	255
F6	65x2x30x31	85	148	70	82	4	M20	240	25	62	195	68.99 _{-0.06}	234	215	292
F7	70x2x30x34	100	180	72	85	4	M20	300	25	72	255	74.18 _{-0.06}	273	250.5	359
F8	85x3x30x27	120	225	90	105	6	M20	350	27	88	298	91.02 _{-0.06}	324	301	422

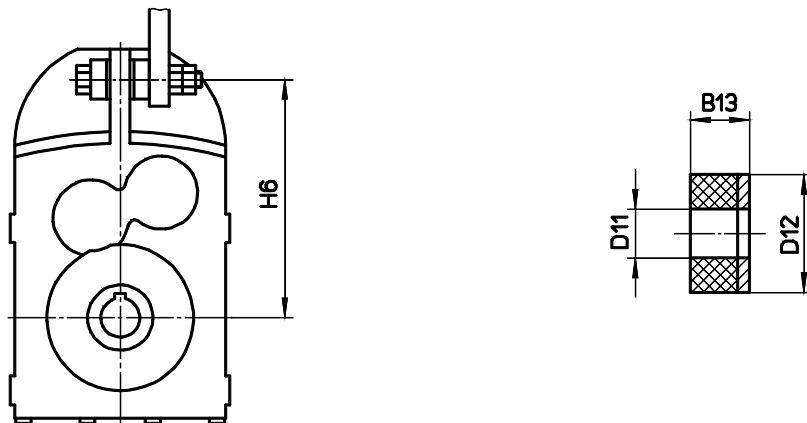
G - Amortisseurs élastiques

Réducteur	B13	D11	D12	H6
F2	15	12.5	30	156
F3	15	12.5	30	182
F4	20	12.5	40	217
F5	30	21	50	270
F6	30	21	60	328
F7	40	25	80	382
F8	40	25	80	458