

1 Safety precautions

	<ul style="list-style-type: none"> Do not reft the inverter unauthorizedly; otherwise fire, electric shock or other injury may occur. Please install the inverter on fire-retardant material and keep the inverter away from combustible materials. Connect the braking optional parts according to the wiring diagram. Do not operate on the inverter if there is any damage or components loss to the inverter. 												
	<ul style="list-style-type: none"> Do not touch the inverter with wet items or body, otherwise electric shock may occur. Only qualified electricians are allowed to operate on the inverter. Do not carry out any wiring and inspection or changing components when the power supply is applied. Ensure all input power supply is disconnected before wiring and checking and always wait for at least the time designated on the inverter or until the DC bus voltage is less than 36V. Below is the table of the waiting time: <table border="1" style="width: 100%; border-collapse: collapse;"> <thead> <tr> <th colspan="2">Inverter module</th> <th>Minimum waiting time</th> </tr> </thead> <tbody> <tr> <td>1PH 220V</td> <td>0.4kW-2.2kW</td> <td>5 minutes</td> </tr> <tr> <td>3PH 220V</td> <td>0.4kW-7.5kW</td> <td>5 minutes</td> </tr> <tr> <td>3PH 380V</td> <td>0.75kW-110kW</td> <td>5 minutes</td> </tr> </tbody> </table>	Inverter module		Minimum waiting time	1PH 220V	0.4kW-2.2kW	5 minutes	3PH 220V	0.4kW-7.5kW	5 minutes	3PH 380V	0.75kW-110kW	5 minutes
Inverter module		Minimum waiting time											
1PH 220V	0.4kW-2.2kW	5 minutes											
3PH 220V	0.4kW-7.5kW	5 minutes											
3PH 380V	0.75kW-110kW	5 minutes											

2 Type designation key

GD20 - 2R2G - 4

① ② ③

Key	No.	Detailed description	Detailed content
Product abbreviation	①	Product abbreviation	GD20 is short for Goodrive20
Rated power	②	Power range + Load type	2R2— 2.2kW G— Constant torque load
Voltage degree	③	Voltage degree	S2: AC 1PH 220V(-15%)-240V(+10%) 2: AC 3PH 220V(-15%)-240V(+10%) 4: AC 3PH 380V(-15%)-440V(+10%)

3 Standard wiring

3.1 Main circuit

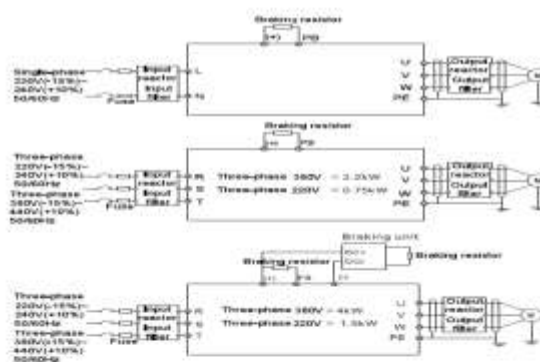

Terminals of main circuit

Terminal	Function
L, N	Single phase AC input terminals which are generally connected with the power supply.
R, S, T	Three phase AC input terminals which are generally connected with the power supply.
PB, (+)	External dynamic braking resistor terminal
(+), (-)	Input terminal of the DBU or DC bus
U, V, W	Three phase AC input terminals which are generally connected with the motor.
PE	Protective grounding terminal

Note:

- Do not use asymmetrically motor cables. If there is a symmetrically grounding conductor in the motor cable in addition to the conductive shield, connect the grounding conductor to the grounding terminal at the inverter and motor ends.
- Route the motor cable, input power cable and control cables separately.

3.2 Control circuit

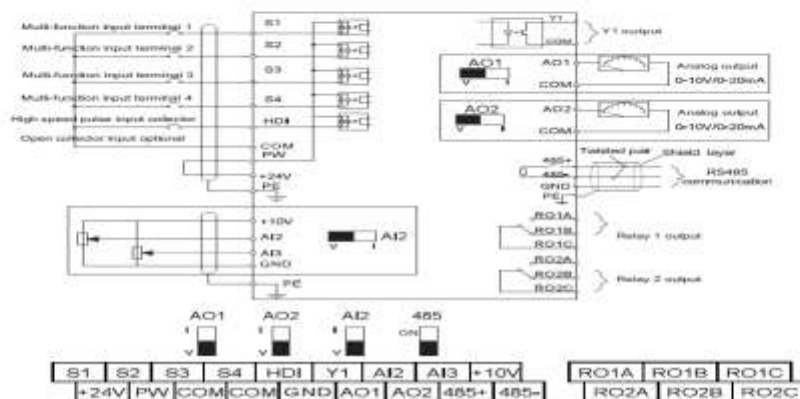

Terminals of control circuit

Terminal name	Technical specifications
485+	485 communication interface
485-	
S1~S4	1. Internal impedance:3.3kΩ 2. 12~30V voltage input is available 3. The terminal is the dual-direction input terminal 4. Max. input frequency:1kHz
HDI	Except for S1~S4, this terminal can be used as high frequency input channel. Max. input frequency:50kHz; Duty cycle:30%~70%
PW	To provide the external digital power supply; Voltage range: 12~30V
Y1	Contact capacity: 50mA/30V
+24V	External 24V ± 10% power supply and the maximum output current is 200mA. Generally used as the operation powersupply of digital input and output or external sensor power supply
COM	
+10V	10V reference power supply; Max. output current: 50mA As the adjusting power supply of the external potentiometer Potentiometer resistance: 5kΩ above
AI2	1. Input range: AI2 voltage and current can be chose: 0~10V/0~20mA;
AI3	AI3:-10V~+10V, 2. Input impedance:voltage input: 20kΩ; current input: 500Ω. 3. Voltage or current input can be setted by dip switch. 4. Resolution: the minimum AI2/AI3 is 10mV/20mV when 10V corresponds to 50Hz.
GND	Analog reference ground
AO1	1. Output range:0~10V or 0~20mA
AO2	2. The voltage or the current output is depended on the dip switch. 3. Deviation±1%,25°C when full range.
RO1A	RO1 relay output, RO1A NO, RO1B NC, RO1C common terminal Contact capacity: 3A/AC250V
RO1B	
RO1C	
RO2A	RO2 relay output, RO2A NO, RO2B NC, RO2C common terminal Contact capacity: 3A/AC250V
RO2B	
RO2C	

4 Diagram of quick start-up

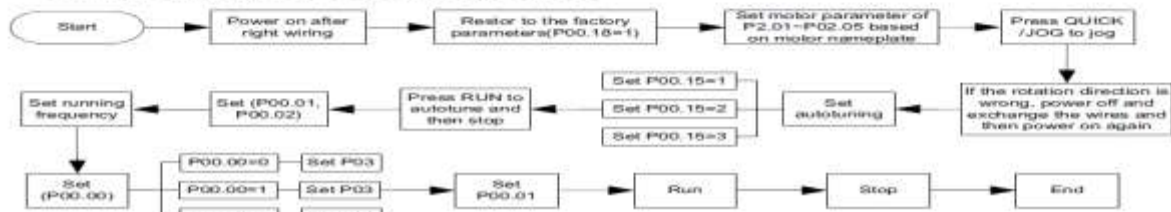

5 Parameters setting

- “○”: means the set value of the parameter can be modified on stop and running state;
- “◐”: means the set value of the parameter can not be modified on the running state;
- “●”: means the value of the parameter is the real detection value which can not be modified.

Note: Automatic check constraints are available to avoid errors for the modifying of the parameters.

Function code	Name	Detailed instruction of parameters	Default value	Modify
P00 Group Basic function group				
P00.00	Speed control mode	0: SVC 0 1: SVC 1 2:SVPWM control	1	○
P00.01	Run command channel	0:Keypad running command channel 1:Terminal running command channel 2:Communication running command channel	0	○
P00.03	Max. output frequency	P00.04~400.00Hz	50.00Hz	○
P00.04	Upper limit of the running frequency	P00.05~P00.03 (Max. output frequency)	50.00Hz	○
P00.05	Lower limit of the running frequency	0.00Hz~P00.04 (Upper limit of the running frequency)	0.00Hz	○
P00.06	A frequency command selection	0:Keypad data setting 1:Analog AI1 setting(corresponding keypad potentiometer)	0	○
P00.07	B frequency command selection	2:Analog AI2 setting(corresponding terminal AI2) 3:Analog AI3 setting(corresponding terminal AI3) 4:High-speed pulse HDI setting 5:Simple PLC program setting 6: Multi-step speed running setting 7: PID control setting 8:MODBUS communication setting	2	○
P00.08	B frequency command reference selection	0:Maximum output frequency. 1: A frequency command.	0	○
P00.09	Combination of the setting source	0: A 1: B 2: A+B 3: A-B 4: Max (A, B) 5: Min (A, B)	0	○
P00.10	Keypad set frequency	0.00 Hz~P00.03 (the Max. frequency)	50.00Hz	○
P00.11	ACC time 1	Setting range of P00.11 and P00.12:0.0~3600.0s	Depend on model	○
P00.12	DEC time 1			
P00.13	Running direction selection	0: Runs at the default direction 1: Runs at the opposite direction 2: Forbid to run in reverse direction	0	○
P00.14	Carrier frequency setting	1.0~15.0kHz	Depend on model	○

Function code	Name	Detailed instruction of parameters	Default value	Modify
P00.15	Motor parameter autotuning	0: No operation 1: Rotation autotuning 2: Static autotuning 1(autotune totally) 3: Static autotuning 2(autotune part parameters)	0	⊙
P00.16	AVR function selection	0:Invalid 1:Valid during the whole procedure	1	○
P00.18	Function restore parameter	0:No operation 1:Restore the default value 2:Clear fault records 3: Lock all function codes	0	⊙
P01 Group Start-up and stop control				
P01.00	Start mode	0:Start-up directly 1:Start-up after DC braking 2: Start after speed tracking 1 3: Start after speed tracking 2	0	⊙
P01.01	Starting frequency of direct start-up	0.00~50.00Hz	0.50Hz	⊙
P01.02	Retention time of the starting frequency	0.0~50.0s	0.0s	⊙
P01.03	The braking current before starting	The setting range of P01.03: 0.0~100.0% The setting range of P01.04: 0.00~50.00s	0.0%	⊙
P01.04	The braking time before starting		0.00s	⊙
P01.05	ACC/DEC selection	0:Linear type 1: S curve	0	⊙
P01.06	ACC time of the starting step of S curve	0.0~50.0s	0.1s	⊙
P01.07	DEC time of the ending step of S curve		0.1s	⊙
P01.08	Stop selection	0: Decelerate to stop 1: Coast to stop	0	○
P01.09	Starting frequency of DC braking	Setting range of P01.09: 0.00Hz~P00.03 (the Max. frequency) Setting range of P01.10: 0.00~50.00s Setting range of P01.11: 0.0~100.0% Setting range of P01.12: 0.00~50.00s	0.00Hz	○
P01.10	Waiting time before DC braking		0.00s	○
P01.11	DC braking current		0.0%	○
P01.12	DC braking time		0.00s	○
P01.13	Dead time of FWD/REV rotation	0.0~3600.0s	0.0s	○
P01.14	Switching between FWD/REV rotation	0:Switch after zero frequency 1:Switch after the starting frequency 2: Switch after the speed reach P01.15 and delay for P01.24	0	⊙
P01.15	Stopping speed	0.00~100.00Hz	0.50Hz	⊙
P01.16	Detection of stopping speed	0: Detect at the setting speed 1: Detect at the feedback speed(only valid for vector control)	1	⊙
P01.17	Detection time of the feedback speed	Setting range: 0.00~100.00s (only valid when P01.16=1)	0.50s	⊙
P01.18	Terminal running protection selection when powering on	0: The terminal running command is invalid when powering on. 1: The terminal running command is valid when powering on.	0	○
P01.19	The running frequency is lower than the lower limit one (valid if the lower limit frequency is above 0)	0: Run at the lower-limit frequency 1: Stop 2: Hibernation	0	⊙
P01.20	Hibernation restore delay time	0.0~3600.0s (valid when P01.19=2)	0.0s	○
P01.21	Restart after power off	0: Disabled 1: Enabled	0	○
P01.22	The waiting time of restart after power off	0.0~3600.0s (valid when P01.21=1)	1.0s	○
P01.23	Start delay time	0.0~60.0s	0.0s	○
P01.24	Delay of the stopping speed	0.0~100.0s	0.0s	○
P01.25	0Hz output	0: Output without voltage 1: Output with voltage 2: Output at the DC braking current	0	○
P02 Group Motor 1				
P02.01	Rated power of asynchronous motor	0.1~3000.0kW	Depend on model	⊙
P02.02	Rated frequency of asynchronous motor	0.01Hz~P00.03	50.00Hz	⊙
P02.03	Rated speed of asynchronous motor	1~3600rpm	Depend on model	⊙
P02.04	Rated voltage of asynchronous motor	0~1200V		○
P02.05	Rated current of asynchronous motor	0.8~6000.0A		○
P02.06	Stator resistor of asynchronous motor	0.001~65.535Ω		○
P02.07	Rotor resistor of asynchronous motor	0.001~65.535Ω		○
P02.08	Leakage inductance of asynchronous motor	0.1~6553.5mH		○
P02.09	Mutual inductance of asynchronous motor	0.1~6553.5mH		○

Function code	Name	Detailed instruction of parameters	Default value	Modify
P02.10	Non-load current of asynchronous motor	0.1~5553.5A		○
P02.11	Magnetic saturation coefficient 1 for the iron core of AM1	0.0~100.0%	80.0%	⊗
P02.12	Magnetic saturation coefficient 2 for the iron core of AM1	0.0~100.0%	68.0%	⊗
P02.13	Magnetic saturation coefficient 3 for the iron core of AM1	0.0~100.0%	57.0%	⊗
P02.14	Magnetic saturation coefficient 4 for the iron core of AM1	0.0~100.0%	40.0%	⊗
P02.26	Motor overload protection selection	0: No protection 1: Common motor (with low speed compensation). 2: Frequency conversion motor (without low speed compensation).	2	⊗
P02.27	Motor overload protection coefficient	Times of motor overload $M = I_{out}/(I_n \cdot K)$ Setting range: 20.0%~120.0%	100.0%	○
P02.28	Correction coefficient of motor 1 power	0.00~3.00	1.00	○
P03 Group Vector control				
P03.00	Speed loop proportional gain 1	The setting range of P03.00 and P03.03: 0~200.0 The setting range of P03.01 and P03.04: 0.000~10.000s The setting range of P03.02: 0.00Hz~P00.05 The setting range of P03.05: P03.02~P00.03	20.0	○
P03.01	Speed loop integral time 1		0.200s	○
P03.02	Low switching frequency		5.00Hz	○
P03.03	Speed loop proportional gain 2		20.0	○
P03.04	Speed loop integral time 2		0.200s	○
P03.05	High switching frequency		10.00Hz	○
P03.06	Speed loop output filter	0~8(corresponds to 0~2 ⁰ /10ms)	0	○
P03.07	Compensation coefficient of vector control electromotion slip	50%~200%	100%	○
P03.08	Compensation coefficient of vector control brake slip		100%	○
P03.09	Current loop percentage coefficient P	0~65535	1000	○
P03.10	Current loop integral coefficient I		1000	○
P03.11	Torque setting method	0: Torque control is invalid 1: Keypad setting torque(P03.12) 2: Analog AI1 setting torque 3: Analog AI2 setting torque 4: Analog AI3 setting torque 5: Pulse frequency HDI setting torque 6: Multi-step torque setting 7: MODBUS communication setting torque	0	○
P03.12	Keypad setting torque	-300.0%~300.0%(motor rated current)	50.0%	○
P03.13	Torque given filter time	0.000~10.000s	0.100s	○
P03.14	Setting source of forward rotation upper-limit frequency in torque control	0: keypad setting upper-limit frequency 1: Analog AI1 setting upper-limit frequency 2: Analog AI2 setting upper-limit frequency 3: Analog AI3 setting upper-limit frequency 4: Pulse frequency HDI setting upper-limit frequency 5: Multi-step setting upper-limit frequency 6: MODBUS communication setting upper-limit frequency	0	○
P03.15	Setting source of reverse rotation upper-limit frequency in torque control		0	○
P03.16	Torque control forward rotation upper-limit frequency keypad defined value	This function is used to set the upper limit of the frequency, P03.16 sets the value of P03.14; P03.17 sets the value of P03.15. Setting range: 0.00 Hz~P00.03 (the Max. output frequency)	50.00 Hz	○
P03.17	Torque control reverse rotation upper-limit frequency keypad defined value		50.00 Hz	○
P03.18	Upper-limit setting of electromotion torque	0: Keypad setting upper-limit frequency 1: Analog AI1 setting upper-limit torque 2: Analog AI2 setting upper-limit torque 3: Analog AI3 setting upper-limit torque 4: Pulse frequency HDI setting upper-limit torque 5: MODBUS communication setting upper-limit torque	0	○
P03.19	Upper-limit setting of braking torque		0	○

Function code	Name	Detailed instruction of parameters	Default value	Modify	
P03.20	Electromotion torque upper-limit keypad setting	0.0~300.0%(motor rated current)	180.0%	○	
P03.21	Braking torque upper-limit keypad setting		180.0%	○	
P03.22	Weakening coefficient in constant power zone	The setting range of P03.22:0.1~2.0 The setting range of P03.23:10%~100%	0.3	○	
P03.23	The lowest weakening point in constant power zone		20%	○	
P03.24	Max. voltage limit	0.0~120.0%	100.0%	⊕	
P03.25	Pre-exciting time	0.000~10.000s	0.300s	○	
P03.26	Weakening proportional gain	0~8000	1200	○	
P03.27	Speed display selection of vector control	0: Display at the actual value 1: Display at the setting value	0	○	
P04 Group SVPWM control					
P04.00	V/F curve setting	1: Multi-dots V/F curve 2: 1.3th power low torque V/F curve 3: 1.7th power low torque V/F curve 4: 2.0th power low torque V/F curve 5: Customized V/F(V/F separation)	0	⊕	
P04.01	Torque boost	The setting range of P04.01: 0.0%:(automatic) 0.1%~10.0%	0.0%	○	
P04.02	Torque boost close	The setting range of P04.02:0.0%~50.0%	20.0%	○	
P04.03	V/F frequency point 1	The setting range of P04.03: 0.00Hz~P04.05 The setting range of P04.04, P04.06 and P04.08 : 0.0%~110.0% (rated motor voltage) The setting range of P04.05:P04.03~ P04.07 The setting range of P04.07:P04.05~P02.02(rated motor voltage frequency)	0.00Hz	○	
P04.04	V/F voltage point 1		0.0%	○	
P04.05	V/F frequency point 2		0.00Hz	○	
P04.06	V/F voltage point 2		0.0%	○	
P04.07	V/F frequency point 3		0.00Hz	○	
P04.08	V/F voltage point 3		0.0%	○	
P04.09	V/F slip compensation gain		$\Delta f = f_r - n \cdot p / 60$ Setting range:0.0~200.0%	100.0%	○
P04.10	Low frequency vibration control factor		The setting range of P04.10:0~100	10	○
P04.11	High frequency vibration control factor	The setting range of P04.11:0~100	10	○	
P04.12	Vibration control threshold	P04.12:0.00Hz~P00.03(the Max. frequency)	30.00 Hz	○	
P04.26	Energy-saving operation selection	0:No operation 1:Automatic energy-saving operation	0	⊕	
P04.27	Voltage Setting channel	0: Keypad setting voltage 1:AI1 setting voltage 2:AI2 setting voltage 3:AI3 setting voltage 4:HDI setting voltage 5:Multi-step speed setting voltage, 6:PID setting voltage; 7:MODBUS communication setting voltage.	0	○	
P04.28	Keypad setting voltage	0.0%~100.0%	100.0%	○	
P04.29	Voltage increasing time		5.0s	○	
P04.30	Voltage decreasing time	0.0~3600.0s	5.0s	○	
P04.31	Output maximum voltage	The setting range of P04.31:P04.32~100.0% (the rated voltage of the motor)	100.0%	⊕	
P04.32	Output minimum voltage	The setting range of P04.32:0.0%~P04.31 (the rated voltage of the motor)	0.0%	⊕	
P04.33	Weakening coefficient in constant power zone	The setting range of P04.33: 1.00~1.30	1.00	○	
P05 Group Input terminals					
P05.00	HDI input selection	0: HDI is high pulse input. 1: HDI is switch input	0	⊕	
P05.01	S1 terminals function selection	0: No function 1: Forward rotation operation	1	⊕	
P05.02	S2 terminals function selection	2: Reverse rotation operation	4	⊕	
P05.03	S3 terminals function selection	3: 3-wire control operation 4: Forward jogging 5: Reverse jogging 6: Coast to stop 7: Fault reset 8: Operation pause	7	⊕	
P05.04	S4 terminals function selection	9: External fault input	0	⊕	
P05.05	S5 terminals function selection	10:Increasing frequency setting(UP) 11:Decreasing frequency setting(DOWN)	0	⊕	
P05.06	S6 terminals function selection	12:Cancel the frequency change setting	0	⊕	
P05.07	S7 terminals function selection	13:Shift between A setting and B setting 14:Shift between combination setting and A setting	0	⊕	
P05.08	S8 terminals function selection	15:Shift between combination setting and B setting	0	⊕	
P05.09	HDI terminals function selection	16:Multi-step speed terminal 1 17:Multi-step speed terminal 2 18:Multi-step speed terminal 3	0	⊕	

Function code	Name	Detailed instruction of parameters	Default value	Modify
		19:Multi-step speed terminal 4 20:Multi-step speed pause 21:ACC/DEC time 1 22:ACC/DEC time 2 23:Simple PLC stop reset 24:Simple PLC pause 25:PID control pause 26:Traverse Pause(stop at the current frequency) 27:Traverse reset(return to the center frequency) 28:Counter reset 29.Torque control prohibition 30:ACC/DEC prohibition 31:Counter trigger 33:Cancel the frequency change setting temporarily 34:DC brake 36:Shift the command to the keypad 37:Shift the command to the terminals 38:Shift the command to the communication 39:Pre-magnetized command 40:Clear the power 41:Keep the power 51:PID pole switching		
P05.32	Lower limit of AI1	0.00V~P05.34	0.00V	○
P05.33	Corresponding setting of the lower limit of AI1	-100.0%~100.0%	0.0%	○
P05.34	Upper limit of AI1	P05.32~10.00V	10.00V	○
P05.35	Corresponding setting of the upper limit of AI1	-100.0%~100.0%	100.0%	○
P05.36	AI1 input filter time	0.000s~10.000s	0.100s	○
P05.37	Lower limit of AI2	0.00V~P05.39	0.00V	○
P05.38	Corresponding setting of the lower limit of AI2	-100.0%~100.0%	0.0%	○
P05.39	Upper limit of AI2	P05.37~10.00V	10.00V	○
P05.40	Corresponding setting of the upper limit of AI2	-100.0%~100.0%	100.0%	○
P05.41	AI2 input filter time	0.000s~10.000s	0.100s	○
P05.42	Lower limit of AI3	-10.00V~P05.44	-10.00V	○
P05.43	Corresponding setting of the lower limit of AI3	-100.0%~100.0%	-100.0%	○
P05.44	Middle value of AI3	P05.42~P05.46	0.00V	○
P05.45	Corresponding middle setting of AI3	-100.0%~100.0%	0.0%	○
P05.46	Upper limit of AI3	P05.44~10.00V	10.00V	○
P05.47	Corresponding setting of the upper limit of AI3	-100.0%~100.0%	100.0%	○
P05.48	AI3 input filter time	0.000s~10.000s	0.100s	○
P05.50	Lower limit frequency of HDI	0.000kHz~P05.52	0.000 kHz	○
P05.51	Corresponding setting of HDI low frequency setting	-100.0%~100.0%	0.0%	○
P05.52	Upper limit frequency of HDI	P05.50~50.000kHz	50.000 kHz	○
P05.53	Corresponding setting of upper limit frequency of HDI	-100.0%~100.0%	100.0%	○
P05.54	HDI frequency input filter time	0.000s~10.000s	0.100s	○
P06 Group Output terminals				
P06.01	Y1 output selection	0: Invalid 1: In operation	0	
P06.03	Relay RO1 output selection	2: Forward rotation operation 3: Reverse rotation operation 4: Jogging operation 5: The inverter fault	1	○
P06.04	Relay RO2 output selection	6: Frequency degree test FDT1 7: Frequency degree test FDT2 8: Frequency arrival 9: Zero speed running 10: Upper limit frequency arrival 11: Lower limit frequency arrival 12: Ready for operation 13: Pre-magnetizing 14: Overload pre-alarm 15: Underload pre-alarm 16: Completion of simple PLC stage 17: Completion of simple PLC cycle 18: Setting count value arrival 19: Defined count value arrival 20: External fault valid 22: Running time arrival 23: MODBUS communication virtual terminals output 26: Establishment of DC bus voltage	5	○
P06.14	AO1 output selection	0:Running frequency 1:Setting frequency	0	○
P06.15	AO2 output selection	2:Ramp reference frequency	0	○

Function code	Name	Detailed instruction of parameters	Default value	Modify
		3:Running rotation speed 4:Output current (relative to 2 times rated current of the inverter) 5:Output current (relative to 2 times rated current of the motor) 6:Output voltage 7:Output power 8:Set torque value 9:Output torque 10:Analog AI1 input value 11:Analog AI2 input value 12:Analog AI3 input value 13:High speed pulse HDI input value 14:MODBUS communication set value 1 15:MODBUS communication set value 2 22:Torque current (corresponds to 3 times rated current of the motor) 23: Ramp reference frequency (with sign)		
P07 Group Human-Machine Interface				
P07.27	Current fault type	0:No fault 4:OC1 5:OC2 6:OC3		●
P07.28	Previous fault type	7:OV1 8:OV2 9:OV3 10:UV		●
P07.29	Previous 2 fault type	11:Motor overload(OL1)		●
P07.30	Previous 3 fault type	12:The inverter overload(OL2)		●
P07.31	Previous 4 fault type	13:Input side phase loss(SPI) 14:Output side phase loss(SPO)		●
P07.32	Previous 5 fault type	15:Overheat of the rectifier module(OH1) 16:Overheat fault of the inverter module(OH2) 17:External fault(EF) 18:485 communication fault(CE) 19:Current detection fault(IE) 20:Motor antotune fault(IE) 21:EEPROM operation fault(EEP) 22:PID response offline fault(PIDE) 24:Running time arriva(END) 25:Electrical overload(OL3) 26:PCE 27:UPE 28:DNE 34:Speed deviation fault(dEu) 35:Maladjustment(STo) 36: Underload fault(LL)		●
P07.33	Current fault running frequency		0.00Hz	●
P07.34	Ramp reference frequency at current fault		0.00Hz	
P07.35	Output voltage at the current fault		0V	
P07.36	Output current at the current fault		0.0A	
P07.37	Current bus voltage at the current fault		0.0V	
P07.38	The Max. temperature at the current fault		0.0°C	
P07.39	Input terminals state at the current fault		0	●
P07.40	Output terminals state at the current fault		0	●
P08 Group Enhanced functions				
P08.27	Setting running time	0~65535min	0min	○
P08.28	Time of fault reset	0~10	0	○
P08.29	Interval time of automatic fault reset	0.1~100.0s	1.0s	○
P08.37	Energy Braking enable	0:Disabled 1:Enabled	0	○
P08.38	Energy braking threshold voltage	200.0~2000.0V	220V voltage: 380.0V 460V voltage: 740.0V	○
P08.39	Cooling fan running mode	0:Rated running mode 1:The fan keeps on running after power on	0	○
P08.50	Magnetic flux braking	0: Invalid. 100~150: the bigger the coefficient, the bigger the braking strength.	0	○
P08.51	Input power factor of the inverter	0.00~1.00	0.56	○
P09 Group PID control				
P09.00	PID reference source	0:Keypad digital given(P09.01) 1:Analog channel AI1 given 2:Analog channel AI2 given 3:Analog channel AI3 set 4:High speed pulse HDI set 5:Multi-step speed set 6:MODBUS communication set	0	○
P09.01	Keypad PID preset	-100.0%~100.0%	0.0%	○
P09.02	PID feedback source	0:Analog channel AI1 feedback 1:Analog channel AI2 feedback	0	○

Function code	Name	Detailed instruction of parameters	Default value	Modify
		2:Analog channel AI3 feedback 3:High speed HOI feedback 4:MODBUS communication feedback		
P09.03	PID output feature	0: PID output is positive 1: PID output is negative	0	<input type="radio"/>
P09.04	Proportional gain (Kp)	0.00~100.00	1.00	<input type="radio"/>
P09.05	Interval time(Ti)	0.00~10.00s	0.10s	<input type="radio"/>
P09.06	Differential time(Td)	0.00~10.00s	0.00s	<input type="radio"/>
P09.07	Sampling cycle(T)	0.001~10.000s	0.100s	<input type="radio"/>
P09.08	PID control deviation limit	0.0~100.0%	0.0%	<input type="radio"/>
P09.09	Output upper limit of PID	P09.10~100.0%	100.0%	<input type="radio"/>
P09.10	Output lower limit of PID	-100.0%~P09.09	0.0%	<input type="radio"/>
P11 Group Protective parameters				
P11.00	Phase loss protection	0x00~0x11 LED ones: 0: Input phase loss protection disable 1: Input phase loss protection enable LED tens: 0: Output phase loss protection disable 1: Output phase loss protection enable	0x10	<input type="radio"/>
P11.01	Frequency-decreasing at sudden power loss	0: Enabled 1: Disabled	0	<input type="radio"/>
P11.02	Frequency decreasing ratio at sudden power loss	0.00Hz/s~P00.03 (the Max. frequency)	10.00 Hz/s	<input type="radio"/>
P11.03	Overvoltage stall protection	0:Disabled 1:Enabled	1	<input type="radio"/>
P11.04	Overvoltage stall voltage protection	120~150%(standard bus voltage)(460V) 120~150%(standard bus voltage)(220V)	136% 115%	<input type="radio"/>
P11.05	Current limit action	Setting range of P11.05:	0x01	<input type="radio"/>
P11.06	Automatic current limit level	0:current limit invalid 1:current limit valid 2:current limit is invalid during constant speed Setting range of P11.05:0x00~0x12	160.0%	<input type="radio"/>
P11.07	The decreasing ratio during current limit	Setting range of P11.06:50.0~200.0% Setting range of P11.07:0.00~50.00Hz/s	10.00 Hz/s	<input type="radio"/>
P11.08	Overload pre-alarm of the motor/ inverter	Setting range of P11.08: 0x000~0x131 LED ones:	0x000	<input type="radio"/>
P11.09	Overload pre-alarm test level	0:Overload pre-alarm of the motor 1:Overload pre-alarm of the inverter LED tens:	150%	<input type="radio"/>
P11.10	Overload pre-alarm detection time	0:The inverter continues to work after underload pre-alarm 1:The inverter continues to work after underload pre-alarm and the inverter stops to run after overload fault 2: The inverter continues to work after overload pre-alarm and the inverter stops to run after underload fault 3. The inverter stops when overloading or underloading. LED hundreds : 0:Detection all the time 1:Detection in constant running Setting range of P11.09: P11.11~200% Setting range of P11.10: 0.1~3600.0s	1.0s	<input type="radio"/>
P11.11	Detection level of the underload pre-alarm	0~P11.09	50%	<input type="radio"/>
P11.12	Detection time of the underload pre-alarm	0.1~3600.0s	1.0s	<input type="radio"/>
P11.13	Output terminal action selection during fault	0x00~0x11 LED ones: 0:Action under fault undervoltage 1:No action under fault undervoltage LED tens: 0:Action during the automatic reset 1:No action during the automatic reset	0x00	<input type="radio"/>
	Speed deviation detection	0.0~50.0%	10.0%	<input type="radio"/>
P11.15	Speed deviation detection time	0.0~10.0s	0.5s	<input type="radio"/>
P11.16	Automatic frequency-decreasing at voltage drop	0:Invalid 1:Valid	0	<input type="radio"/>

More instructions

Please contact with us for any information. It is necessary to provide the product model and serial number during consultation. Following modes are available:
 Visit www.invt.com: Contact with INVT local offices;
 Visit mobile website <http://m.invt.com>.
 Please refer to the operation manual of Goodrive20 inverters for detailed information.
 Please download the operation manual of Goodrive20 inverters on www.invt.com.



Part number: 66001-00345

INVT Copyright.

Information may be subject to change without notice during product improving

201608(V1.0)